

Anritsu envision : ensure

Signal Analyzer MS2690A/MS2691A/MS2692A
Signal Analyzer MS2840A/MS2830A

MX2690xxA series Measurement Software



MX2690xxA series Measurement Software

Signal Analyzers MS269xA, MS2830A and MS2840A

The Signal Analyzer MS269xA is the high-end model supporting best-of-class high-accuracy, a wide dynamic range and 125 MHz wideband analysis.

The MS2840A and MS2830A are the mid-range model with excellent cost performance supporting superior RF performance, best-of-class speed, and low power consumption.

	MS269xA (High-end model)	MS2840A (Middle-range model)	MS2830A (Middle-range model)
Feature	<ul style="list-style-type: none"> High level accuracy up to 6 GHz expandable to 4G, and 125 MHz wideband 177 dB dynamic range without external filter for spurious measurements 	<ul style="list-style-type: none"> Highest level phase noise performance among middle-range models Highest level phase noise performance among middle-range models Built-in high-performance CPU and SSD storage for much faster display of signal analyzer results, etc. 	<ul style="list-style-type: none"> High-speed, low-cost, low power-consumption cuts manufacturing costs Environment-friendly energy saving design
Frequency Range	50 Hz to 6 GHz 50 Hz to 13.5 GHz 50 Hz to 26.5 GHz	9 kHz to 3.6 GHz 9 kHz to 6 GHz 9 kHz to 26.5 GHz 9 kHz to 44.5 GHz	9 kHz to 3.6 GHz 9 kHz to 6 GHz 9 kHz to 13.5 GHz 9 kHz to 26.5 GHz 9 kHz to 43 GHz
Analysis Bandwidth	31.25 MHz 62.5 MHz (Option) 125 MHz (Option)	31.25 MHz 62.5 MHz (Option)*1 125 MHz (Option)*1	None 10 MHz (Option) 31.25 MHz (Option) 62.5 MHz (Option)*1 125 MHz (Option)*1
Residual Vector Error*2	W-CDMA/HSPA Downlink: $\leq 1.0\%$ (rms) W-CDMA/HSPA Uplink: $\leq 1.0\%$ (rms) LTE Downlink: $< 1.0\%$ (rms) LTE Uplink: $< 1.0\%$ (rms) QPSK, 16QAM, $\pi/4$ DQPSK, etc.: $< 0.5\%$ (rms)	QPSK, 16QAM, $\pi/4$ DQPSK, etc.: $< 1.0\%$ (rms)	W-CDMA/HSPA Downlink: $\leq 1.3\%$ (rms) W-CDMA/HSPA Uplink: $\leq 1.2\%$ (rms) LTE Downlink: $< 1.3\%$ (rms) LTE Uplink: $< 1.2\%$ (rms) QPSK, 16QAM, $\pi/4$ DQPSK, etc.: $< 1.0\%$ (rms)

*1: An image response is received when setting the bandwidth to more than 31.25 MHz.

This can be used when not inputting a signal frequency outside the MS2840A/MS2830A analysis bandwidth (125 MHz max.).

The Signal Analyzer MS2690A/91A/92A series is recommended for other measurement purposes.

*2: Note that the residual vector error performance of the MS269xA and MS2840A/MS2830A is different due to the difference in basic performance. Refer to the specifications page for the specifications for other residual vector error software.

Main Frame Measurement Functions

The MS269xA, MS2840A and MS2830A series of signal analyzers has the following built-in spectrum analyzer and signal analyzer functions used in combination with measurement software.

- Spectrum
- Spectrum Emission Mask
- FM Deviation
- Frequency Counter
- Frequency vs. Time
- Channel Power
- Burst Average Power
- Multi-marker & Marker List
- 2-tone 3rd-order Intermodulation Distortion
- Phase vs. Time
- Occupied Bandwidth
- Spurious Emission
- Highest 10 Markers
- Annotation Display
- CCDF/APD*
- Adjacent Channel Leakage Power
- AM Depth
- Limit Line
- Power vs. Time
- Spectrogram

*: CCDF: Complementary Cumulative Distribution Function, APD: Amplitude Probability Density



Adjacent Channel Leakage Power

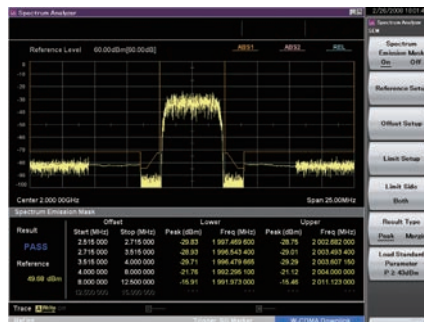

Spectrum Emission Mask

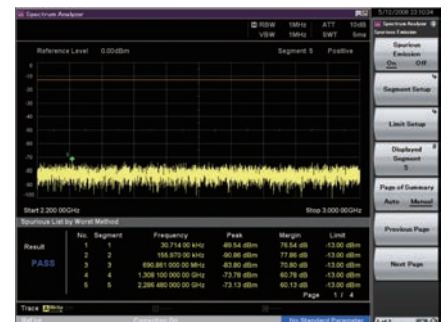

Spurious Emission

MX2690xxA series Measurement Software

Signal Analyzers MS269xA, MS2830A and MS2840A

Hardware Option (Measurement Functions)

The following measurement functions can be added as hardware options to the MS269xA, MS2840A, and MS2830A series of signal analyzers (depending on the model). For details refer to the relevant main-frame catalog.

Phase Noise Measurement Function, Noise Figure Measurement Function, Precompliance EMI Function

MX2690xxA series Measurement Software

The MX2690xxA series of measurement software can be used by the MS269xA, MS2840A and MS2830A.

Installing this software adds modulation analysis for each communication system to the MS269xA, MS2840A and MS2830A.

The platforms supported by the MX2690xxA are shown below.

✓ = Can be installed, R = Require, U = Upgrade

Communications Systems	Name	Model	Page	MS269xA	MS269xA	MS2840A	MS2840A	MS2830A	MS2830A Option		
					Option 077/078		Option 077/078		Option 006	Option 005/009	Option 077/078
Mobile WiMAX	Mobile WiMAX Measurement Software	MX269010A	6	✓				✓	R	R	
W-CDMA/HSPA/ HSPA Evolution	W-CDMA/HSPA Downlink Measurement Software	MX269011A	8	✓				✓	R		
	W-CDMA/HSPA Uplink Measurement Software	MX269012A	10	✓				✓	R		
GSM/EDGE	GSM/EDGE Measurement Software	MX269013A	12	✓				✓	R		
EDGE Evolution	EDGE Evolution Measurement Software	MX269013A-001*8	12	✓				✓	R		
ETC/DSRC	ETC/DSRC Measurement Software	MX269014A	14	✓							
TD-SCDMA	TD-SCDMA Measurement Software	MX269015A	16	✓				✓	R		
World Digital Wireless Standards	Vector Modulation Analysis Software	MX269017A	18	✓	U*15	✓	U*15	✓	R	U*15	U*15
Analog (FM/øM/AM)	Analog Measurement Software	MX269018A*9	26			✓		✓			
LTE/ LTE-Advanced (FDD)	LTE Downlink Measurement Software	MX269020A	35	✓				✓	R	R	
	LTE-Advanced FDD Downlink Measurement Software	MX269020A-001*10	35	✓	U*16			✓	R	R*16	U*16
	LTE Uplink Measurement Software	MX269021A	41	✓				✓	R	R	
	LTE-Advanced FDD Uplink Measurement Software	MX269021A-001*20	41	✓	U			✓	R	R	U
LTE/ LTE-Advanced (TDD)	LTE TDD Downlink Measurement Software	MX269022A	35	✓				✓	R	R	
	LTE-Advanced TDD Downlink Measurement Software	MX269022A-001*11	35	✓	U*16			✓	R	R*16	U*16
	LTE TDD Uplink Measurement Software	MX269023A	41	✓				✓	R	R	
	LTE-Advanced TDD Uplink Measurement Software	MX269023A-001*21	41	✓	U			✓	R	R	U
CDMA2000	CDMA2000 Forward Link Measurement Software	MX269024A	47	✓				✓	R		
	All Measure Function	MX269024A-001	47	✓				✓	R		
1xEV-DO	EV-DO Forward Link Measurement Software	MX269026A	47	✓				✓	R		
	All Measure Function	MX269026A-001	47	✓				✓	R		
Femtocell	TRX Sweep Calibration	MX283087A	69					✓	R	R	
WLAN	WLAN (802.11) Measurement Software (Supports IEEE 802.11n/11p/11a/11b/11g/11j)	MX269028A	50	✓				✓	R	R	
	802.11ac (80 MHz) Measurement Software	MX269028A-001*12	50					✓	R	R*17	R*17
	802.11ac (160 MHz) Measurement Software	MX269028A-002*12	50	✓	R*17						
W-CDMA/HSPA	W-CDMA BS Measurement Software	MX269030A	60	✓				✓	R		
WLAN	Wireless Network Device Test Software	MX283027A	62					✓			
	WLAN Test Software (Supports IEEE 802.11n/11a/11b/11g)	MX283027A-001*13, *14	62					✓	R	R	
Bluetooth	Bluetooth Test Software	MX283027A-002*13	62					✓	R	R	

MX2690xxA series Measurement Software

Signal Analyzers MS269xA, MS2830A and MS2840A

Note, the MS269xA and MS2830A require the following options:

[MS269xA Options]

Analysis Bandwidth Extension to 62.5 MHz MS269xA-077
 Analysis Bandwidth Extension to 125 MHz*1 MS269xA-078

[MS2840A Options]

Analysis Bandwidth Extension to 62.5 MHz MS2840A-077
 Analysis Bandwidth Extension to 125 MHz*2 MS2840A-078

[MS2830A Options]

Analysis Bandwidth Extension to 31.25 MHz*3 MS2830A-005
 Analysis Bandwidth 10 MHz MS2830A-006
 Bandwidth Extension to 31.25 MHz for Millimeter-wave*4 MS2830A-009
 Bandwidth Extension to 31.25 MHz for Millimeter-wave*4 MS2830A-009
 Analysis Bandwidth Extension to 62.5 MHz*5, *7 MS2830A-077
 Analysis Bandwidth Extension to 125 MHz*6, *7 MS2830A-078

*1: MS269xA-077 is necessary.

*2: MS2840A-077 is necessary.

*3: Available only when MS2830A-040/041/043/044 is installed. Requires MS2830A-006.

*4: Available only when MS2830A-045 is installed. Requires MS2830A-006.

*5: Requires MS2830A-006 and MS2830A-005 (for MS2830A-040/041/043/044).
 Requires MS2830A-006 and MS2830A-009 (for MS2830A-045).

*6: Requires MS2830A-006, MS2830A-005, and MS2830A-077 (for MS2830A-040/041/043/044).
 Requires MS2830A-006, MS2830A-009, and MS2830A-077 (for MS2830A-045).

*7: An image response is received when setting the bandwidth to more than 31.25 MHz.
 This can be used when not inputting a signal frequency outside the MS2830A analysis bandwidth (125 MHz max.).
 The Signal Analyzer MS2690A/91A/92A series is recommended for other measurement purposes.

*8: Requires MX269013A

*9: MS2830A-066 and A0086B required by MS2830A; A0086B required by MS2840A.

*10: Requires MX269020A

*11: Requires MX269022A

*12: Requires MX269028A

*13: Requires MX283027A

*14: MX283027A-001 includes WLAN IQproducer MX269911A (Cannot order MX283027A-001 and MX269911A at same time).

*15: The Symbol Rate setting range varies as follows, depending on the option configuration.

Model			Modulation Method			
MS269xA	MS2840A	MS2830A	O-QPSK	FSK	Except FSK	
					Frame Formatted	Non-Formatted
MS269xA-078, 077 installed	MS2840A-078, 077 installed	MS2830A-078, 077, 005/009, 006 installed	0.1 ksp/s to 12.5 Msps	0.1 ksp/s to 25 Msps	0.1 ksp/s to 50 Msps	0.1 ksp/s to 140 Msps
MS269xA-077 installed	MS2840A-077 installed	MS2830A-077, 005/009, 006 installed	0.1 ksp/s to 6.25 Msps	0.1 ksp/s to 12.5 Msps	0.1 ksp/s to 25 Msps	0.1 ksp/s to 70 Msps
Standard	Standard	MS2830A-005/009, 006 installed	0.1 ksp/s to 3.125 Msps	0.1 ksp/s to 6.25 Msps	0.1 ksp/s to 12.5 Msps	0.1 ksp/s to 35 Msps
—	—	MS2830A-006 installed	0.1 ksp/s to 1.25 Msps	0.1 ksp/s to 2.5 Msps	0.1 ksp/s to 5 Msps	0.1 ksp/s to 5 Msps

*16: The LTE-Advanced Carrier Aggregation measurement range varies as follows, depending on the Analysis Bandwidth Extension option configuration.

Main frame	Analysis Bandwidth Extension Option	Maximum Analysis Bandwidth (In-band carrier aggregation range)	Maximum Number of Band	Maximum Number of Component Carrier
MS269xA	MS269xA-078 installed	125 MHz	3	5
	MS269xA-077 installed	31.25 MHz	3	5
	Standard	31.25 MHz	3	5
MS2830A	MS2830A-078 installed	125 MHz	1	5
	MS2830A-077 installed	31.25 MHz	3	5
	MS2830A-005/009 installed	31.25 MHz	3	5

*17: The IEEE 802.11ac measurement range varies as follows, depending on the Analysis Bandwidth Extension option configuration.

Model		Bandwidth of IEEE 802.11ac signal					
Main frame	Measurement software	Analysis Bandwidth Extension Option Configuration	20 MHz	40 MHz	80 MHz	160 MHz	80 MHz + 80 MHz
MS269xA	MX269028A-002	MS269xA-078 installed	✓	✓	✓	✓	✓*18
		MS269xA-077 installed	✓	✓			
		Standard	✓	✓			
MS2830A	MX269028A-001	MS2830A-078 installed	✓	✓	✓*19		
		MS2830A-077 installed	✓	✓			
		MS2830A-005/009 installed	✓	✓			

*18: Measurement required for each carrier signal (80 MHz bandwidth)

*19: Measurement is only possible when the carrier signal (80 MHz bandwidth) is input due to the effect of the image response.

*20: Requires MX269021A

*21: Requires MX269023A

MX2690xxA series Measurement Software

Signal Analyzers MS269xA, MS2830A and MS2840A

Measurement Software for Smart Meter (For MS269xA and MS2830A)

This software is for PC. This software supports automatic measurement of the PHY layer and protocol analysis of the PHY/MAC layer of smart utility network wireless communications (Wi-SUN).

Wi-SUN PHY Measurement Software*1 MX705010A
Wi-SUN Protocol Monitor*2 MX705110A

The MX705010A*1 supports automatic measurement of Wi-SUN Alliance PHY Conformance test cases. The MS269xA/MS2830A is controlled by remote commands from this software.

★1: Cannot be installed in MS269xA/MS2830A.

Requires the latest firmware of MS269xA/MS2830A.

This service, which provides updated versions of firmware and software for downloading by product customers, is available on Anritsu's website.

<<https://www.my.anritsu.com/home>>

Main frame	Options configuration examples
MS269xA	MX269017A, MS269xA-020, MX269902A
MS2830A	MS2830A-041, MS2830A-002, MS2830A-006, MX269017A, MS2830A-020, MS2830A-022, MS2830A-027, MX269902A

MX705110A*2 supports Wi-SUN protocol analysis. The wireless signals*3 between communicating devices are captured as I/Q data using the MS269xA digitize function and data analysis is performed by this software. Data analysis displays the PHY/MAC frame format, Tx timing, etc.

★2: Cannot be installed in MS269xA/MS2830A.

Requires the latest firmware of MS269xA/MS2830A.

MS2830A-006 is necessary for MS2830A.

★3: IEEE 802.15.4g/e (GFSK)

WiMAX® is a trademark or registered trademark of WiMAX Forum.

CDMA2000® is a registered trademark of the Telecommunications Industry Association (TIA-USA).

Wi-SUN® is a registered trademark of Wi-SUN Alliance.

The Mobile WiMAX Measurement Software MX269010A supports measurement of IEEE 802.16e RF Tx characteristics. Installing it in the MS269xA and MS2830A supports fast, high-accuracy measurements ideal for efficient R&D and early rollout of Mobile WiMAX base stations, mobile terminals, and components.

Versatile Functions for Mobile WiMAX Development

Mobile WiMAX Measurement Software supports modulation analysis and transmit power measurement required for development of Mobile WiMAX base stations, mobile terminals, and device components.

■ Downlink Measurement Functions

- Frequency Offset
- Vector Error (EVM) [Peak/rms]
- CINR
- Preamble Power
- Downlink Average Power
- Timing Error
- Constellation
- Power spectrum vs. Subcarrier
- Power vs. Time
- I/Q data vs. Subcarrier
- Map Information
- EVM vs. Subcarrier
- EVM vs. Symbol
- Spectral Flatness

■ Uplink Measurement Functions

- Frequency Offset
- Vector Error (EVM) [Peak/rms]
- Channel Power
- Unmodulated subcarrier error
- Pilot subcarrier power
- Data subcarrier power
- Null subcarrier power
- Constellation
- Power spectrum vs. Subcarrier
- Power vs. Time
- EVM vs. Subcarrier
- EVM vs. Symbol
- Spectral Flatness

Specifications

The specification is the value after 30-minute warm-up at a constant ambient temperature.

The specifications are defined under the following condition unless otherwise specified.

Attenuator mode: Mechanical Attenuator Only (MS2830A only)

Signal Analyzer		MS269xA	MS2830A	
Modulation/ Frequency Measurement	Analysis Length	5 ms, Cyclic Prefix: 1/4, 1/8, 1/16, 1/32		
	Bandwidth	20, 10, 8.75, 7, 5, 3.5 MHz		
	Modulation Method	64QAM, 16QAM, QPSK		
	Measurement Frequency Range	2.3 GHz to 3.8 GHz		
	Measurement Level Range	-15 to +30 dBm (Preamp Off, or Preamp not installed) -30 to +20 dBm (Preamp On)	-15 to +30 dBm (Preamp Off, or Preamp not installed)	
	Carrier Frequency Measurement Accuracy	At 18° to 28°C, after calibration ± (Accuracy of reference frequency × Carrier frequency + 20 Hz)		
Residual Vector Error	At 18° to 28°C, after calibration <0.6% (rms) (Under 10 MHz BW) <0.8% (rms) (20 MHz BW)		<1.6% (rms) (Under 10 MHz BW) <1.8% (rms) (20 MHz BW)	
	Spectral Flatness Accuracy	±0.3 dB		
Amplitude Measurement	Tx Power Measurement Accuracy (This is found from root sum of squares (RSS) of absolute amplitude accuracy and in-band frequency characteristics of main frame.)	At 18° to 28°C, after calibration ±0.6 dB (Preamp Off, or Preamp not installed) ±1.1 dB (Preamp On)		
		±0.6 dB (Preamp Off, or Preamp not installed)		

Measurement Functions

- **Modulation**

This function displays the constellation and subcarrier spectrum for a specified symbol along with frequency error, EVM, power, etc., results as text. It is useful for finding symbol-dependent faults.



Modulation

- **EVM vs. Symbol**

The EVM distribution for each symbol is displayed. This can be used to find instantaneous symbol-dependent EVM degradation.



EVM vs. Symbol

- **Map Information**

The distribution (map) of the DL burst is displayed with logical subchannel on the vertical axis and symbol on the horizontal axis. The burst information and modulation accuracy are displayed for the specified burst.

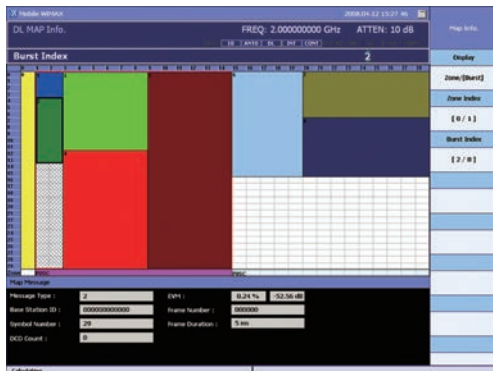

Map Information

- **Spectral Flatness**

The Absolute Flatness Display indicates the difference between the average power and power of each subcarrier; the Differential Flatness Display indicates the power difference between adjacent subcarriers.



Spectral Flatness

- **EVM vs. Subcarrier**

The EVM distribution of each subcarrier at the specified symbol is displayed. This can be used to find instantaneous subcarrier-dependent EVM degradation.



EVM vs. Subcarrier

- **MIMO Signal Measurement**

The modulation accuracy, frequency error, Tx power, spectral flatness, etc., for both ANT 0 and ANT 1 MIMO signals are measured by switching between ANT 0 and ANT 1.

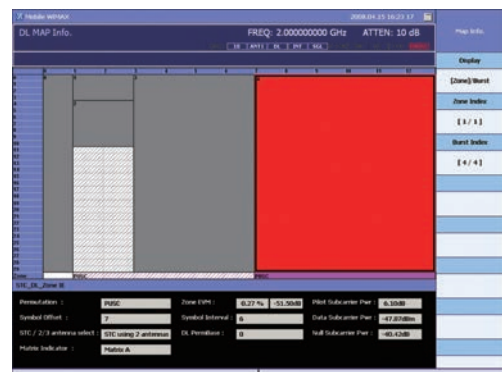

Map Information (ANT 1)

The W-CDMA/HSPA Downlink Measurement Software MX269011A supports measurement of the RF Tx characteristics of W-CDMA/HSDPA/HSUPA/HSPA Evolution base stations.

Installing it in the MS269xA and MS2830A supports fast, high-accuracy measurements ideal for efficient R&D and early rollout of base stations and base-station components.

Versatile Functions for W-CDMA/HSPA/HSPA Evolution Development

Modulation analysis, Tx Power measurements, etc., required for development of W-CDMA/HSPA/HSPA Evolution base stations and device components are performed at high speed with superior accuracy.

■ Modulation Analysis

- Frequency Error
- Mean Power
- Vector Error/Amplitude Error/Phase Error
- Origin Offset
- Peak Code Domain Error
- Constellation
- Vector Error/Amplitude Error/Phase Error vs. Chip

■ Code Domain

- Mean Power
- P-CPICH/P-SCH/S-SCH
- Vector Error/Amplitude Error/Phase Error
- Code Power
- Code Domain/Code Domain Error
- Constellation
- Vector Error/Amplitude Error/Phase Error/Code Power vs. Symbol

■ Code vs. Time

- Mean Power
- P-CPICH/P-SCH/S-SCH
- Vector Error/Amplitude Error/Phase Error
- Code Power
- Code vs. Time
- Code Domain/Code Domain Error

■ Spectrum

- Adjacent Channel Leakage Power
- Channel Power
- Occupied Bandwidth
- Spectrum Emission Mask

Specifications

The specification is the value after 30-minute warm-up at a constant ambient temperature.

The specifications are defined under the following condition unless otherwise specified.

Attenuator mode: Mechanical Attenuator Only (MS2830A only)

Signal Analyzer		MS269xA	MS2830A
Common Specifications	Target Signals	W-CDMA/HSPA/HSPA Evolution Downlink	
Modulation/ Frequency Measurement	Measurement Frequency Range	400 MHz to 3 GHz	
	Measurement Level Range	-15 to +30 dBm (Preamp Off, or Preamp not installed) -30 to +10 dBm (Preamp On)	-15 to +30 dBm (Preamp Off, or Preamp not installed)
	Carrier Frequency Measurement Accuracy	At 18° to 28°C, after calibration, EVM = 1% signal ± (Accuracy of reference frequency × Carrier frequency + 5 Hz)	± (Accuracy of reference frequency × Carrier frequency + 6 Hz)
	Residual Vector Error	At 18° to 28°C, after calibration, When input signal within measurement level range and less than input level ≤1.0% (rms)	≤1.3% (rms)
Amplitude Measurement	Tx Power Measurement Accuracy (This is found from root sum of squares (RSS) of absolute amplitude accuracy and in-band frequency characteristics of main frame.)	At 18° to 28°C, after calibration, Input attenuator ≥10 dB, When input signal within measurement level range and less than input level ±0.6 dB (Preamp Off, or Preamp not installed) ±1.1 dB (Preamp On)	±0.6 dB (Preamp Off, or Preamp not installed)
Code Domain Measurement	Code Domain Power	At 18° to 28°C, after calibration, When input signal within measurement level range and less than input level Relative Accuracy: ±0.02 dB (Code Power ≥10 dBc) ±0.05 dB (Code Power ≥20 dBc) ±0.10 dB (Code Power ≥30 dBc)	Relative Accuracy: ±0.02 dB (Code Power ≥10 dBc) ±0.10 dB (Code Power ≥20 dBc) ±0.15 dB (Code Power ≥30 dBc)
	Code Domain Error	Relative Accuracy: ≤-46 dB Accuracy: ±0.3 dB (Code Domain Error ≥-30 dBc) ±1.0 dB (Code Domain Error ≥-40 dBc)	Relative Accuracy: ≤-42 dB
	Waveform Display	EVM vs. Symbol, Amplitude Error vs. Symbol, Phase Error vs. Symbol, Symbol Constellation, Code Domain Power, Code Domain Error	
Spectrum Measurement	Measurement Functions	Adjacent Channel Leakage Power, Channel Power, Occupied Bandwidth, Spectrum Emission Mask	

Measurement Functions

- **Frequency Error/Modulation Accuracy**

This function supports modulation analysis of W-CDMA/HSDPA/HSUPA/HSPA Evolution downlink signals with simultaneous display of max and mean values of frequency and vector error, etc., for up to 15 slots to evaluate DUT dispersion characteristics.

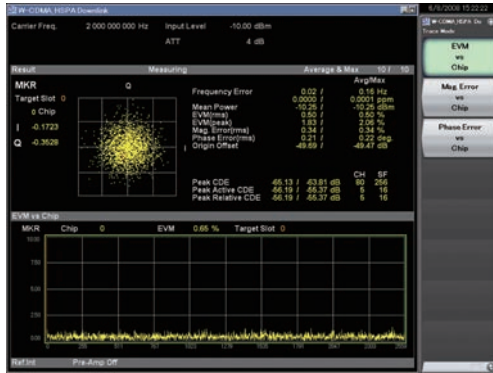

Modulation Analysis Screen

- **Code Domain**

This function displays results for each code as a constellation and numeric table, making it easy to discover transient code-dependent signal degradation.

In addition, graphs can be displayed with any of Vector Error, Amplitude Error, and Phase Error on the vertical axis to discover transient time-dependent (symbol units) signal degradation for a specific code.



Code Domain (Constellation)

- **Code vs. Time**

This function is convenient for monitoring time variations in Mean Power for all codes and Code Power for up to 300 slots. It is useful when performing tests specified by 3GPP TS 25.141, 6.4.1 Inner Loop Power Control and 6.4.2 Power Control Steps.



Code vs. Time



Code Domain (Vector Error vs. Symbol)

The W-CDMA/HSPA Uplink Measurement Software MX269012A supports measurement of the RF Tx characteristics of W-CDMA/HSDPA/HSUPA/HSPA Evolution mobile terminals.

Installing it in the MS269xA and MS2830A supports fast, high-accuracy measurements ideal for efficient R&D and early rollout of mobile terminals and mobile-terminal components.

Versatile Functions for W-CDMA/HSPA/HSPA Evolution Development

Modulation analysis, Tx Power measurements, etc., required for development of W-CDMA/HSPA/HSPA Evolution mobile terminals and device components are performed at high speed with superior accuracy.

■ Modulation Analysis

- Frequency Error
- Mean Power
- Vector Error/Amplitude Error/Phase Error
- Origin Offset
- Peak Code Domain Error
- Constellation
- Vector Error/Amplitude Error/Phase Error vs. Chip

■ Code Domain

- Mean Power
- Vector Error/Amplitude Error
- Code Power
- Code Domain/Code Domain Error
- Constellation
- Vector Error/Amplitude Error/Code Power vs. Symbol

■ Spectrum

- Adjacent Channel Leakage Power
- Channel Power
- Occupied Bandwidth
- Spectrum Emission Mask

Specifications

The specification is the value after 30-minute warm-up at a constant ambient temperature.

The specifications are defined under the following condition unless otherwise specified.

Attenuator mode: Mechanical Attenuator Only (MS2830A only)

Signal Analyzer		MS269xA	MS2830A
Common Specifications	Target Signal	W-CDMA/HSPA/HSPA Evolution Uplink	
Modulation/ Frequency Measurement	Measurement Frequency Range	400 MHz to 3 GHz	
	Measurement Level Range	-15 to +30 dBm (Preamp Off, or Preamp not installed) -30 to +10 dBm (Preamp On)	-15 to +30 dBm (Preamp Off, or Preamp not installed)
	Carrier Frequency Measurement Accuracy	At 18° to 28°C, after calibration, EVM = 1% signal ± (Accuracy of reference frequency × Carrier frequency + 5 Hz)	± (Accuracy of reference frequency × Carrier frequency + 6 Hz)
	Residual Vector Error	At 18° to 28°C, after calibration, When input signal within measurement level range and less than input level ≤1.0% (rms)	≤1.2% (rms)
Amplitude Measurement	Tx Power Measurement Accuracy (This is found from root sum of squares (RSS) of absolute amplitude accuracy and in-band frequency characteristics of main frame.)	At 18° to 28°C, after calibration, Input attenuator ≥10 dB, When input signal within measurement level range and less than input level ±0.6 dB (Preamp Off, or Preamp not installed) ±1.1 dB (Preamp On)	±0.6 dB (Preamp Off, or Preamp not installed)
	Code Domain Measurement	At 18° to 28°C, after calibration, When input signal within measurement level range and less than input level	
Code Domain Power		Relative Accuracy: ±0.02 dB (Code Power ≥-10 dBc) ±0.05 dB (Code Power ≥-20 dBc) ±0.10 dB (Code Power ≥-30 dBc)	Relative Accuracy: ±0.02 dB (Code Power ≥-10 dBc) ±0.10 dB (Code Power ≥-20 dBc) ±0.15 dB (Code Power ≥-30 dBc)
Code Domain Error		Residual Error: ≤-46 dB Accuracy: ±0.3 dB (Code Domain Error ≥-30 dBc) ±1.0 dB (Code Domain Error ≥-40 dBc)	Residual Error: ≤-42 dB
Spectrum Measurement	Waveform Display	EVM vs. Symbol, Amplitude Error vs. Symbol, Vector Error vs. Symbol, Symbol Constellation, Code Domain Error, Code Domain Power	
	Measurement Functions	Adjacent Channel Leakage Power, Channel Power, Occupied Bandwidth, Spectrum Emission Mask	

Measurement Functions

- **Frequency Error/Mean Power/Modulation Accuracy**

The Frequency Error, Mean Power, and Modulation Accuracy are displayed simultaneously as a constellation and graphs showing changes in Vector Error/Amplitude Error/Phase Error over time (Chip units). Instantaneous characteristics can be measured due to the excellent residual EVM characteristics of the MS269xA.

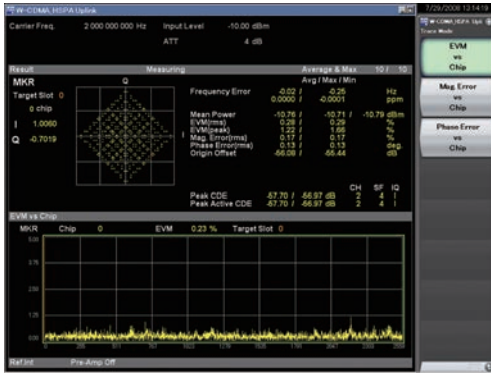

Constellation and Vector Error vs. Chip

- **Code Domain**

Code Power and Code Errors can be displayed simultaneously as a specified code constellation and as graphs showing changes in Vector Error/Amplitude Error/Code Power over time (Symbol units). These time domain graphs allow the designer to find demodulation errors between RF and baseband.

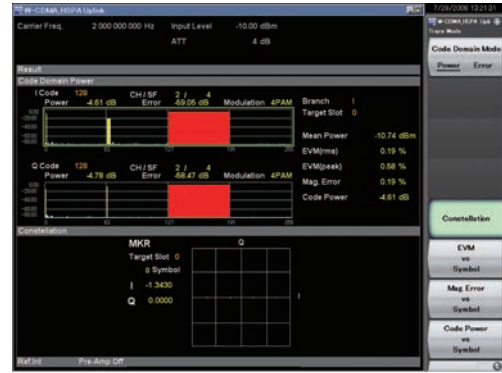

Code Domain Power and Constellation

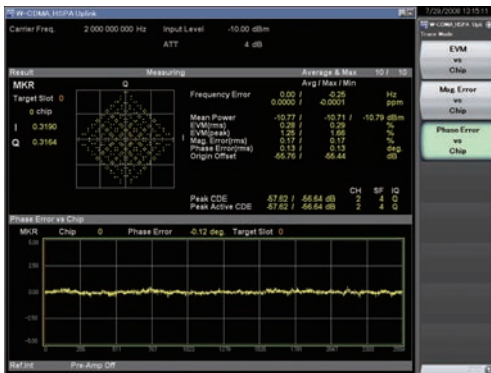

Constellation and Phase Error vs. Chip



Code Domain Power and Code Power vs. Symbol

MX2690xxA series Measurement Software

GSM/EDGE Measurement Software MX269013A EDGE Evolution Measurement Software MX269013A-001 (Continued)

MS269xA

MS2830A

The GSM/EDGE Measurement Software MX269013A and EDGE Evolution Measurement Software MX269013A-001 support measurement of the RF Tx characteristics of GSM/EDGE (EGPRS) and EDGE Evolution (EGPRS2) signals.

Installation in the MS269xA and MS2830A supports fast, high-accuracy measurements ideal for efficient R&D and early rollout of GSM/EDGE/EDGE Evolution base stations, mobile terminals, and terminal components.

Versatile Functions for GSM/EDGE/EDGE Evolution R&D

Supports the fast, high-accuracy modulation analysis and mean power measurements required for development of GSM/EDGE/EDGE Evolution base stations, mobile terminals, and components.

■ Modulation Analysis (GMSK)

- Frequency Error
- Phase Error (Peak/rms)
- Constellation
- Phase Error vs. Symbol

■ Modulation Analysis (QPSK, 8PSK, 16QAM, 32QAM)

- Frequency Error
- Vector Error (EVM) [Peak/rms]
- Magnitude Error/Phase Error (rms)
- Origin Offset
- 95th percentile
- Droop
- Constellation
- EVM/Magnitude Error/Phase Error vs. Symbol

■ Output Spectrum Measurement

- Spectrum due to Modulation
- Spectrum due to Switching Transients

■ Power vs. Time

- Slot Power
- Slot Status
- Symbol Power Graph
- Time Offset

Specifications

The specification is the value after 30-minute warm-up at a constant ambient temperature.

The specifications are defined under the following condition unless otherwise specified.

Attenuator mode: Mechanical Attenuator Only (MS2830A only)

Signal Analyzer		MS269xA	MS2830A
Shared Specifications	Supported Signals	GSM/EDGE Downlink and uplink (MX269013A) EDGE Evolution Downlink and Uplink (MX269013A-001)	
	Modulation Method	GMSK, 8PSK (Normal Burst, Continuous) (MX269013A) QPSK, 16QAM, 32QAM (Normal Burst, Higher Symbol Rate Burst, Continuous) (MX269013A-001)	
Modulation/ Frequency Measurement	Measured Frequency Range	400 MHz to 2 GHz	
	Measured Level Range	-15 to +30 dBm (Preamp Off, or Preamp not installed) -30 to +10 dBm (Preamp On)	-15 to +30 dBm (Preamp Off, or Preamp not installed)
	Carrier Frequency Measurement Accuracy	At 18° to 28°C, after calibration, with EVM = 1% signal ± (Accuracy of reference frequency × Carrier frequency + 5 Hz)	
	Residual Vector Error (QPSK, 8PSK, 16QAM, 32QAM)	At 18° to 28°C, after calibration, with input signal in measurement level range and less than Input level ≤0.6% (rms)	± (Accuracy of reference frequency × Carrier frequency + 8 Hz) ≤1.0% (rms)
	Residual Phase Error (GMSK)	At 18° to 28°C, after calibration, with input signal in measurement level range and less than Input level ≤0.5 deg (rms)	≤0.7 deg (rms)
	Waveform Display (MX269013A)	Constellation, Phase Error vs. Symbol, EVM vs. Symbol (at 8PSK only), Magnitude Error vs. Symbol (at 8PSK only)	
	Waveform Display (MX269013A-001)	Constellation, Phase Error vs. Symbol, EVM vs. Symbol, Magnitude Error vs. Symbol	
Amplitude Measurement	Tx Power Measurement Accuracy (This is found from root sum of squares (RSS) of absolute amplitude accuracy and in-band frequency characteristics of main frame.)	At 18° to 28°C, after calibration, with input attenuator ≥10 dB and input signal in measurement level range and less than Input level ±0.6 dB (Preamp Off, or Preamp not installed) ±1.1 dB (Preamp On)	±0.6 dB (Preamp Off, or Preamp not installed)
	Waveform Display	Rise, Fall, Slot, Frame	
Output RF Spectrum Measurement	Modulation Part Measurement Points	At 18° to 28°C, after calibration, with input attenuator ≥10 dB input signal 0 to +30 dBm (at preamp Off, or no preamp installed), carrier frequency of 400 MHz to 2000 MHz, 5-pole filter ±100, ±200, ±250, ±400, ±600, ±800, ±1000, ±1200, ±1400, ±1600, ±1800, ±3000, ±6000 kHz	
	Modulation Part Measurement Range	<-41 dB (100 kHz detuning), <-66 dB (200 kHz detuning), <-74 dB (250 kHz detuning), <-79 dB (400 kHz detuning), <-80 dB (<1200 kHz detuning), <-83 dB (<1800 kHz detuning), <-80 dB (≥1800 kHz detuning)	—
	Switching Transients part Measurement Points	±400, ±600, ±1200, ±1800 kHz	
	Switching Transients part Measurement Range	<-71 dB (400 kHz detuning), <-72 dB (600 kHz detuning), <-75 dB (1200 kHz detuning), <-75 dB (1800 kHz detuning)	—

MX2690xxA series Measurement Software

GSM/EDGE Measurement Software MX269013A EDGE Evolution Measurement Software MX269013A-001 (Continued)

MS269xA

MS2830A

Measurement Functions

• Frequency Error/Modulation Accuracy

As well as displaying frequency error, modulation accuracy and numeric average and maximum values, the constellation and temporal changes in vector, amplitude and phase errors can be displayed simultaneously as graphs (symbol units) to monitor symbol-dependent changes in modulation accuracy.

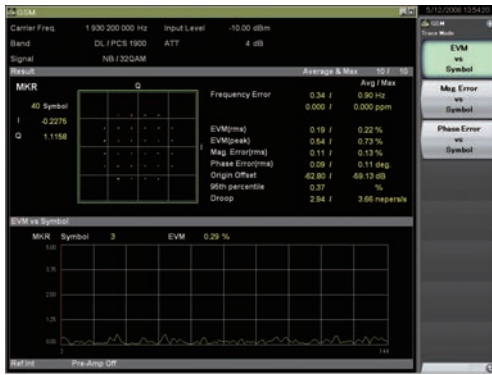

• Power vs. Time

Variations in power with time are monitored at rise/fall, slot and frame displays to support Pass/Fail evaluation. The burst characteristics are easily understood from the single average, max. and min. display.



Rise/Fall (Average)

• Output Spectrum Measurements

The power spectrum is measured from the center frequency to a specified offset frequency. Modulation measures the spectrum due to modulation near the burst center; Switching Transients measures the spectrum due to the burst wave rise/fall.



Modulation Part

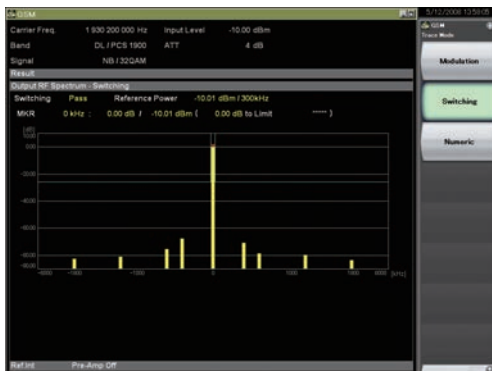

Switching Transients Part



Slot (Average)

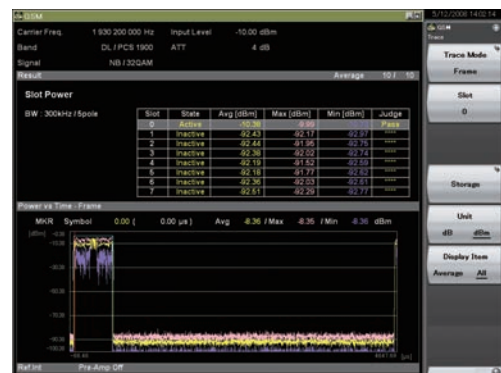

Frame (Average/Max./Min.)

The ETC/DSRC Measurement Software MX269014A supports measurement of the RF Tx characteristics of ARIB STD T75 narrow-band wireless devices.

Installing it in the MS269xA supports fast, high-accuracy measurements ideal for efficient R&D, early rollout, and evaluation of DSRC wireless devices.

High-accuracy and High-speed Measurements Support Higher Manufacturing Efficiency

The MS269xA series supports modulation analysis and spectrum measurement for manufacturing and servicing DSRC wireless equipment. High-accuracy measurements are supported by extending the baseband upper frequency limit to 6 GHz. The ± 0.6 dB accuracy for Tx power measurement in the 5.8-GHz band using ETC/DSRC improves yield, while manufacturing and inspection times are cut to 110 ms* and 190 ms*, respectively, for analyzing $\pi/4$ DQPSK and ASK modulation signals to improve production throughout.

*: Average with graph display OFF (reference value); approximately 120 ms ($\pi/4$ DQPSK) and 350 ms (ASK) with graph display ON.

■ Modulation Analysis ($\pi/4$ DQPSK)

- Frequency Error
- Tx Power
- Vector Error (EVM) [Peak/rms]
- Origin Offset
- Droop Factor
- Constellation

■ Modulation Analyzer (ASK)

- Frequency Error
- Tx Power
- Peak Power
- Modulation Index
- Eye Opening
- Eye Diagram

■ Spectrum

- Adjacent Channel Leakage Power
- Occupied Bandwidth

Specifications

The specification is the value after 30-minute warm-up at a constant ambient temperature.

Signal Analyzer		MS269xA
Common Specifications	Modulation Method	$\pi/4$ DQPSK, ASK
	Target Signals	Downlink, Uplink
	Target Channel	MDC
Modulation/ Frequency Measurement	Measurement Frequency Range	5700 MHz to 5900 MHz
	Measurement Level Range	-15 to +30 dBm (Preamp Off, or Preamp not installed) -30 to +10 dBm (Preamp On)
	Carrier Frequency Measurement Accuracy	At 18° to 28°C, after calibration, with EVM = 1% signal \pm (Accuracy of reference frequency \times Carrier frequency + 20 Hz)
	Residual Vector Error	At 18° to 28°C, after calibration, when modulation is $\pi/4$ DQPSK <1.0% (rms)
Amplitude Measurement	Tx Power Measurement Accuracy (This is found from root sum of squares (RSS) of absolute amplitude accuracy and in-band frequency characteristics of main frame.)	At 18° to 28°C, after calibration, with input attenuator ≥ 10 dB and input signal in measurement level range and less than Input level ± 0.6 dB (Preamp Off, or Preamp not installed) ± 1.1 dB (Preamp On)
Waveform Display	Modulation/Frequency	Constellation ($\pi/4$ DQPSK), Eye Diagram (ASK)
	Spectrum	Adjacent Channel Leakage Power, Occupied Bandwidth

Measurement Functions

- **Modulation Analysis ($\pi/4$ DQPSK)**

This analysis displays the $\pi/4$ DQPSK modulation signal results along with a constellation graph. The dispersion of RF characteristics is measured easily using simultaneous display of maximum and average values.



- **Modulation Analysis (ASK)**

This analysis displays the ASK modulation signal results along with an eye diagram.

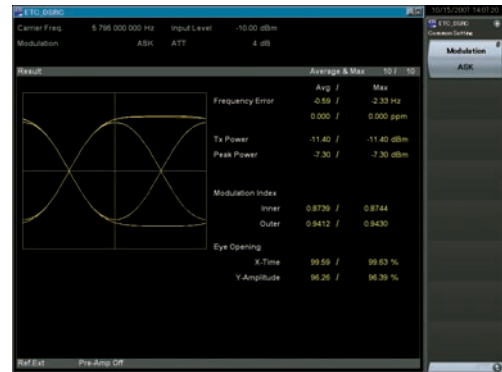

The TD-SCDMA Measurement Software MX269015A supports measurement of the TRx characteristics of TD-SCDMA 3G digital mobile devices. Installing it in the MS269xA and MS2830A supports fast, high-accuracy measurements ideal for R&D and early rollout of base stations, repeaters, mobile terminals, and components.

Supports Various Functions for R&D and Manufacturing of TD-SCDMA Wireless Equipment and Devices

Modulation analysis and spectrum measurement results can be displayed as both numeric values and graphs.

The efficiency of base station and repeater tests is increased by using the Multi Carrier and Multi Slot Power measurement functions as well as the Multi Carrier Adjacent Channel Leakage Power measurement function.

■ Modulation Analysis

- Frequency Error
- Tx Power
- Vector Error (EVM) [Peak/rms]
- Origin Offset
- Peak Code Domain Error
- Constellation
- Code Domain Graph
- Multi-Carrier Power
- Multi-Slot Power

■ Spectrum

- Adjacent Channel Leakage Power (ACLR)
- Occupied Bandwidth (OBW)
- Spectrum Emission Mask (SEM)

■ Power vs. Time

- Time Mask
- Off Power
- On Power
- TSi Power
- Power vs. Time Graph

Specifications

The specification is the value after 30-minute warm-up at a constant ambient temperature.

The specifications are defined under the following condition unless otherwise specified.

Attenuator mode: Mechanical Attenuator Only (MS2830A only)

Signal Analyzer		MS269xA	MS2830A
Common Specifications	Channel Bandwidth	1.6 MHz	
	Target Signal	Downlink, Uplink	
Modulation/ Frequency Measurement	Measurement Frequency Range	1850 MHz to 2620 MHz	
	Measurement Level Range	-15 to +30 dBm (Preamp Off, or Preamp not installed) -30 to +10 dBm (Preamp On)	-15 to +30 dBm (Preamp Off, or Preamp not installed)
	Carrier Frequency Measurement Accuracy	At 18° to 28°C, after calibration, with EVM = 1% signal ± (Accuracy of reference frequency × Carrier frequency + 20 Hz)	
	Modulation Accuracy	At 18° to 28°C, after calibration, input signal in measurement level range and less than Input level Residual EVM: ≤1.0% (rms)	
Amplitude Measurement	Tx Power Measurement Accuracy (This is found from root sum of squares (RSS) of absolute amplitude accuracy and in-band frequency characteristics of main frame.)	At 18° to 28°C, after calibration, with input attenuator ≥10 dB and input signal in measurement level range and less than Input level	
		±0.6 dB (Preamp Off, or Preamp not installed) ±1.1 dB (Preamp On)	±0.6 dB (Preamp Off, or Preamp not installed)
Code Domain Measurement		At 18° to 28°C, after calibration, input signal in measurement level range and less than Input level	
	Code Domain Power	Relative Accuracy: ±0.18 dB (Code Power ≥-10 dBc) ±0.32 dB (Code Power ≥-30 dBc)	
	Code Domain Error	Residual Error: ≤-40 dB Accuracy: ±1.0 dB (Code Domain Error ≥-40 dBc)	
	Waveform Displays	Code Domain Power, Code Domain Error, IQ Constellation	
Spectrum Measurement	Measurement Functions	Adjacent Channel Leakage Power, Occupied Bandwidth, Spectrum Emission Mask, Power vs. Time	

Measurement Functions

- **Frequency Error/Tx Power/Modulation Accuracy**

The Frequency Error, Tx Power, and Modulation Accuracy for the specified carrier slot are displayed simultaneously as constellation and code domain power graphs. Instantaneous characteristics can be measured due to the excellent residual EVM characteristics of the MS269xA.

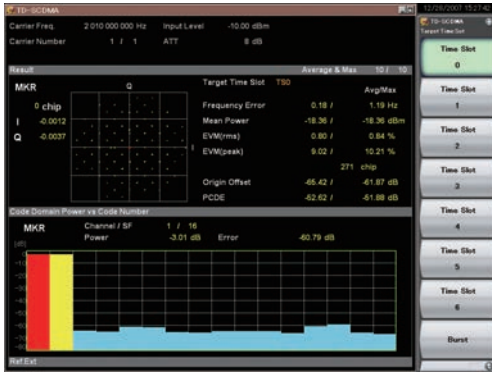

Constellation and Code Domain Power

- **Multi Carrier/Multi Slot Power Measurements**

The Multi Carrier measurement function simultaneously displays the Tx Power for all carriers and slots of the multi carrier signal, while the Multi Slot Power measurement function simultaneously displays the mean and partial Tx Powers for all slots.



Multi Carrier Power

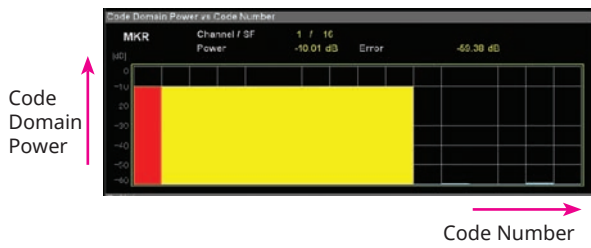

Code Domain Power vs. Code Number



Multi Slot Power

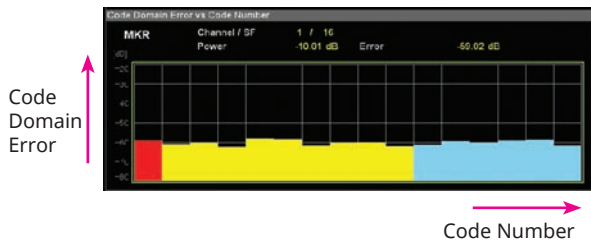

Code Domain Error vs. Code Number

- **Power vs. Time Measurements**

Provides measurements for Transmitter OFF Power and Time Mask. This function can be used only in MS269xA series.



Power vs. Time

The Vector Modulation Analysis software MX269017A supports various digital wireless modulation analyses. Installing it in the MS269xA, MS2840A and MS2830A supports fast, high-accuracy measurements ideal for R&D and early rollout of digital radio equipment and components serving a wide range of applications, ranging from public safety and private industry* to aerospace and satellite communications.

*: Can measure APCO-P25 Phase1/Phase2, NXDN, ARIB STD-T98, T102, etc.

Versatile Functions for Digital Wireless Communication Development

Fast and high-accuracy modulation analysis for R&D into digital radio equipment and components for public, aerospace, and satellite applications.

■ Numeric result display

BPSK, QPSK, O-QPSK, $\pi/4$ DQPSK, 8PSK, 16QAM, 64QAM, 256QAM

- Tx Power
- Filtered Power
- Frequency Error (Hz, ppm)
- Vector Error (EVM) [Peak/rms]
- Offset Vector Error (EVM) [Peak/rms] (O-QPSK)
- Phase Error (Peak/rms)
- Magnitude Error (Peak/rms)
- Symbol Rate Error
- Specific Word (Hex)
- Origin Offset
- Droop Factor (BPSK, $\pi/4$ DQPSK, 8PSK)
- IQ Gain Imbalance (QPSK, O-QPSK, $\pi/4$ DQPSK, 8PSK, 16QAM, 64QAM, 256QAM)
- Quadrature Error (QPSK, O-QPSK, $\pi/4$ DQPSK, 8PSK, 16QAM, 64QAM, 256QAM)
- MER (Peak/rms)
- Timing Offset

2FSK, 4FSK

- Tx Power
- Filtered Power
- Frequency Error (Hz, ppm)
- Magnitude Error (Peak/rms)
- FSK Error (Peak/rms)
- BER
- Modulation Fidelity (Peak/rms)
- Symbol Rate Error
- Specific Word (Hex)
- Jitter (P-P Min., P-P Max.)
- Deviation (Average, +Peak, -Peak, (Peak-Peak)/2)
- Deviation at Ts/2 (Average, +Max. Peak, +Min. Peak, -Max. Peak, -Min. Peak, (Peak-Peak)/2, +Max. Peak%, -Min. Peak%)
- Timing Offset

2ASK

- Tx Power
- Filtered Power
- Frequency Error (Hz, ppm)
- Vector Error (EVM) [Peak/rms]
- Magnitude Error (Peak/rms)
- Droop Factor
- BER
- MER (Peak/rms)
- Symbol Rate Error
- Specific Word (Hex)
- Modulation Index (rms)
- Eye Opening (X-Time)
- Eye Opening (Y-Amplitude)
- Timing Offset

■ Graph display

BPSK, QPSK, O-QPSK, $\pi/4$ DQPSK, 8PSK, 16QAM, 64QAM, 256QAM

- Constellation
- EVM vs. Symbol
- Magnitude Error vs. Symbol
- Phase Error vs. Symbol
- Trellis
- Eye Diagram
- I and Q vs. Symbol
- Magnitude vs. Symbol
- Phase vs. Symbol
- Signal Monitor
- Symbol Table
- Equalizer Amplitude
- Equalizer Phase
- Equalizer Group Delay
- Equalizer Impulse Response

2FSK, 4FSK, H-CPM*

- Constellation
- EVM vs. Symbol
- Magnitude Error vs. Symbol
- Phase Error vs. Symbol
- Frequency vs. Symbol
- Trellis
- Eye Diagram
- I and Q vs. Symbol
- Magnitude vs. Symbol
- Phase vs. Symbol
- Signal Monitor
- Symbol Table
- FSK Error vs. Symbol
- Fidelity vs. Symbol

2ASK, 4ASK

- Constellation
- EVM vs. Symbol
- Magnitude Error vs. Symbol
- Phase Error vs. Symbol
- Frequency vs. Symbol
- Trellis
- Eye Diagram
- I and Q vs. Symbol
- Magnitude vs. Symbol
- Signal Monitor
- Symbol Table

MX2690xxA series Measurement Software

Vector Modulation Analysis Software MX269017A (Continued)

MS269xA

MS2840A

MS2830A

Specifications

The specification is the value after 30-minute warm-up at a constant ambient temperature.

The specifications are defined under the following condition unless otherwise specified.

Attenuator mode: Mechanical Attenuator Only (MS2830A only)

Common Specifications

Signal Analyzer		MS269xA	MS2840A	MS2830A			
Measurement Symbol Rate Range	BPSK, QPSK, π /4DQPSK, 8PSK, 16QAM, 64QAM, 256QAM, 2ASK, 4ASK	0.1 ksp/s to 12.5 Msps	0.1 ksp/s to 12.5 Msps (MS2840A-006/009 installed)	0.1 ksp/s to 12.5 Msps (MS2830A-005/009, 006 installed) 0.1 ksp/s to 5 Msps (MS2830A-006 installed)			
	2FSK, 4FSK	0.1 ksp/s to 6.25 Msps	0.1 ksp/s to 6.25 Msps (MS2840A-006/009 installed)	0.1 ksp/s to 6.25 Msps (MS2830A-005/009, 006 installed) 0.1 ksp/s to 2.5 Msps (MS2830A-006 installed)			
Symbol Rate Setting Range	Model		Modulation Method				
	MS269xA	MS2840A	MS2830A	O-QPSK	2FSK 4FSK	Other than following Frame Formatted	Non-Formatted
	MS269xA-078, 077 installed	MS2840A-078, 077 installed	MS2830A-078, 077, 005/009, 006 installed	0.1 ksp/s to 12.5 Msps	0.1 ksp/s to 25 Msps	0.1 ksp/s to 50 Msps	0.1 ksp/s to 140 Msps
	MS269xA-077 installed	MS2840A-077 installed	MS2830A-077, 005/009, 006 installed	0.1 ksp/s to 6.25 Msps	0.1 ksp/s to 12.5 Msps	0.1 ksp/s to 25 Msps	0.1 ksp/s to 70 Msps
	Standard	Standard	MS2830A-005/009, 006 installed	0.1 ksp/s to 3.125 Msps	0.1 ksp/s to 6.25 Msps	0.1 ksp/s to 12.5 Msps	0.1 ksp/s to 35 Msps
—	—	MS2830A-006 installed	0.1 ksp/s to 1.25 Msps	0.1 ksp/s to 2.5 Msps	0.1 ksp/s to 5 Msps	0.1 ksp/s to 5 Msps	
Modulation method		BPSK, QPSK, O-QPSK, π /4DQPSK, 8PSK, 16QAM, 64QAM, 256QAM, 2FSK, 4FSK, 2ASK, 4ASK					

Frequency Setting Range

MS269xA				
Condition				Frequency Setting Range
Option	Modulation Type	Measuring Object	Symbol Rate	
With MS269xA-067/167	BPSK, QPSK, π /4DQPSK, 8PSK, 16QAM, 64QAM, 256QAM, 2ASK, 4ASK	Frame Format	>12.5 Msps	100 MHz to the upper limit of the main unit
		Non-Formatted (Span Up = On)	>12.5 Msps	100 MHz to the upper limit of the main unit
		Non-Formatted (Span Up = Off)	>35 Msps	100 MHz to the upper limit of the main unit
	2FSK, 4FSK	—	>6.25 Msps	100 MHz to the upper limit of the main unit
O-QPSK	—	>3.125 Msps	100 MHz to the upper limit of the main unit	
Without MS269xA-067/167	BPSK, QPSK, π /4DQPSK, 8PSK, 16QAM, 64QAM, 256QAM, 2ASK, 4ASK	Frame Format	>12.5 Msps	100 MHz to 6 GHz
		Non-Formatted (Span Up = On)	>12.5 Msps	100 MHz to 6 GHz
		Non-Formatted (Span Up = Off)	>35 Msps	100 MHz to 6 GHz
	2FSK, 4FSK	—	>6.25 Msps	100 MHz to 6 GHz
O-QPSK	—	>3.125 Msps	100 MHz to 6 GHz	
Other than above				100 kHz to the upper limit of the main unit

MS2840A				
MS2830A				
Condition				Frequency Setting Range
Option	Modulation Type	Measuring Object	Symbol Rate	
With MS2840A-067/167, MS2830A-067/167	BPSK, QPSK, π /4DQPSK, 8PSK, 16QAM, 64QAM, 256QAM, 2ASK, 4ASK	Frame Format	>12.5 Msps	300 MHz to the upper limit of the main unit
		Non-Formatted (Span Up = On)	>12.5 Msps	300 MHz to the upper limit of the main unit
		Non-Formatted (Span Up = Off)	>35 Msps	300 MHz to the upper limit of the main unit
	2FSK, 4FSK	—	>6.25 Msps	300 MHz to the upper limit of the main unit
O-QPSK	—	>3.125 Msps	300 MHz to the upper limit of the main unit	
Without MS2840A-067/167, MS2830A-067/167	BPSK, QPSK, π /4DQPSK, 8PSK, 16QAM, 64QAM, 256QAM, 2ASK, 4ASK	Frame Format	>12.5 Msps	300 MHz to 6 GHz or the upper limit of the main unit, whichever is lower.
		Non-Formatted (Span Up = On)	>12.5 Msps	300 MHz to 6 GHz or the upper limit of the main unit, whichever is lower.
		Non-Formatted (Span Up = Off)	>35 Msps	300 MHz to 6 GHz or the upper limit of the main unit, whichever is lower.
	2FSK, 4FSK	—	>6.25 Msps	300 MHz to 6 GHz or the upper limit of the main unit, whichever is lower.
O-QPSK	—	>3.125 Msps	300 MHz to 6 GHz or the upper limit of the main unit, whichever is lower.	
Other than above				100 kHz to the upper limit of the main unit

MX2690xxA series Measurement Software

Vector Modulation Analysis Software MX269017A (Continued)

MS269xA

MS2840A

MS2830A

■ Modulation/Frequency Measurement

Signal Analyzer		MS269xA	MS2840A	MS2830A
Measurement Level Range		-15 to +30 dBm (Preamp Off, or Preamp not installed) -25 to +10 dBm (Preamp On)		
Carrier Frequency Measurement Accuracy	BPSK, QPSK, 8PSK, 16QAM, 64QAM, 256QAM, 2FSK, 4FSK	At 18° to 28°C, after calibration, with EVM = 1% signal ± (Accuracy of reference frequency × Carrier frequency + 10 Hz) (Center Frequency: 30 MHz to 6.0 GHz) (Note that a range of 3 GHz or above is not available when MS269xA-003 is installed and with Frequency Band Mode set to Spurious.)		± (Accuracy of reference frequency × Carrier frequency + 10) Hz (Center Frequency: 30 MHz to 3.5 GHz)
	$\pi/4$ DQPSK, 2ASK, 4ASK	At 18° to 28°C, after calibration, with EVM = 1% signal ± (Accuracy of reference frequency × Carrier frequency + 10) Hz (Center Frequency: 30 MHz to 6.0 GHz) (Note that a range of 3 GHz or above is not available when MS269xA-003 is installed and with Frequency Band Mode set to Spurious.)		± (Accuracy of reference frequency × Carrier frequency + 10) Hz (Center Frequency: 30 MHz to 3.5 GHz) ± (Accuracy of reference frequency × Carrier frequency + 10) Hz (Center Frequency: 5.7 GHz to 5.9 GHz, nom.)
Residual Vector Error	BPSK, QPSK, 8PSK, 16QAM, 64QAM, 256QAM	At 18° to 28°C, after calibration, Filter type: Root Nyquist or Nyquist, when input signal within measurement level range and less than input level, 20-times averaging <0.5% (rms) Symbol rate: 4 ksps to 500 ksps Measurement time length: ≤50 ms Carrier Frequency: 50 MHz to 500 MHz <1.0% (rms) Symbol rate: 500 ksps to 5 Msps Carrier Frequency: 50 MHz to 6 GHz (Note that a range of 3 GHz or above is not available when MS269xA-003 is installed and with Frequency Band Mode set to Spurious.)		<1.0% (rms) Symbol rate: 4 ksps to 500 ksps Measurement time length: ≤50 ms Carrier Frequency: 50 MHz to 500 MHz <1.5% (rms) Symbol rate: 500 ksps to 5 Msps Carrier Frequency: 50 MHz to 3.5 GHz
	$\pi/4$ DQPSK	At 18° to 28°C, after calibration, Filter type: Root Nyquist or Nyquist, when input signal within measurement level range and less than input level, 20-time averaging <0.5% (rms) Symbol rate: 4 ksps to 500 ksps Measurement time length: ≤50 ms Carrier Frequency: 50 MHz to 500 MHz <1.0% (rms) Symbol rate: 500 ksps to 5 Msps Carrier Frequency: 50 MHz to 6 GHz (Note that a range of 3 GHz or above is not available when MS269xA-003 is installed and with Frequency Band Mode set to Spurious.)		<1.0% (rms) Symbol rate: 4 ksps to 500 ksps Measurement time length: ≤50 ms Carrier Frequency: 50 MHz to 500 MHz <1.5% (rms) Symbol rate: 500 ksps to 5 Msps Carrier Frequency: 50 MHz to 3.5 GHz <1.5% (rms) (nom.) Symbol rate: 500 ksps to 5 Msps Carrier Frequency: 5.7 GHz to 5.9 GHz
Symbol Rate Error		After CAL execution at 18° to 28°C, according to the 10 MHz common reference*, when: Modulation Type: 2FSK, Filter Type: Gaussian, BT=0.5, Symbol Rate 100 ksps, slot length 160 symbol, The signal measured is within the measurement level range and less than or equal to Input Level, and Average = 10 times 30 MHz to 6 GHz <±1.0ppm (Note that a range of 3 GHz or above is not available when MS269xA-003 is installed and with Frequency Band Mode set to Spurious.)		30 MHz to 3.5 GHz <±1.0ppm

*: Connect 10 MHz Reference between signal source and signal analyzer

■ Amplitude Measurement

Signal Analyzer		MS269xA	MS2840A	MS2830A
Measurement Level Range		-15 to +30 dBm (Preamp Off, or Preamp not installed) -25 to +10 dBm (Preamp On)	-15 to +30 dBm (Preamp Off, or Preamp not installed)	
Tx Power Measurement Accuracy (This is found from root sum of squares (RSS) of absolute amplitude accuracy and in-band frequency characteristics of main frame.)		At 18° to 28°C, after calibration, with input attenuator ≥10 dB and input signal in measurement level range and less than Input level 30 MHz to 6 GHz ± 0.6 dB (at Pre-Amp Off, or Pre-Amp not installed.) ± 1.1 dB (at Pre-Amp On) (Note that a range of 3 GHz or above is not available when MS269xA-003 is installed and with Frequency Band Mode set to Spurious.)		30 MHz to 3.5 GHz ± 0.6 dB (at Pre-Amp Off, or Pre-Amp not installed.)

MX2690xxA series Measurement Software

Vector Modulation Analysis Software MX269017A (Continued)

MS269xA

MS2840A

MS2830A

Measurement Functions

A maximum of eight traces can be measured using the results for four traces displayed in four panes on one screen. Instantaneous toggling between two screens supports at-a-glance monitoring of eight traces.

Measurement Functions

Trace Mode	Modulation Type		
	BPSK QPSK O-QPSK $\pi/4$ DQPSK 8PSK 2ASK 4ASK	16QAM 64QAM 256QAM	2FSK 4FSK H-CPM*
Constellation	✓	✓	✓
EVM vs. Symbol	✓	✓	✓
Magnitude Error vs. Symbol	✓	✓	✓
Phase Error vs. Symbol	✓	✓	✓
Frequency vs. Symbol	—	—	✓
Trellis	✓	✓	✓
Eye Diagram	✓	✓	✓
Numeric	✓	✓	✓
I and Q vs. Symbol	✓	✓	✓
Magnitude vs. Symbol	✓	✓	✓
Phase vs. Symbol	✓	✓	✓
Signal Monitor	✓	✓	✓
Symbol Table	✓	✓	✓
Equalizer Amplitude	✓	✓	—
Equalizer Phase	✓	✓	—
Equalizer Group Delay	✓	✓	—
Equalizer Impulse Response	✓	✓	—
FSK Error vs. Symbol	—	—	✓
Fidelity vs. Symbol	—	—	✓
Histogram	—	—	✓
Custom Numeric	✓	✓	✓

✓: Displays measured results.

—: Does not display measured results.

*: Used at APCO-P25 Phase2 Inbound measurement



4-pane Screen (Traces 1-4)

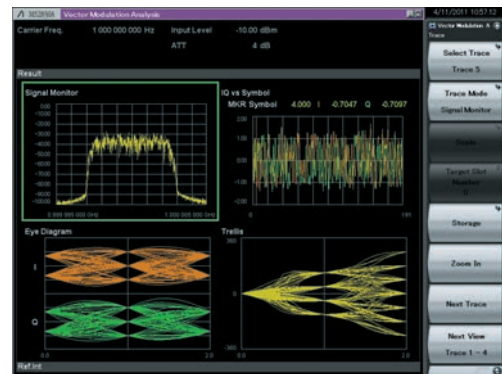

4-pane Screen (Traces 5-8)

Double-clicking the screen toggles between the four-pane and zoom screens to raise design verification efficiency through optimized operability.

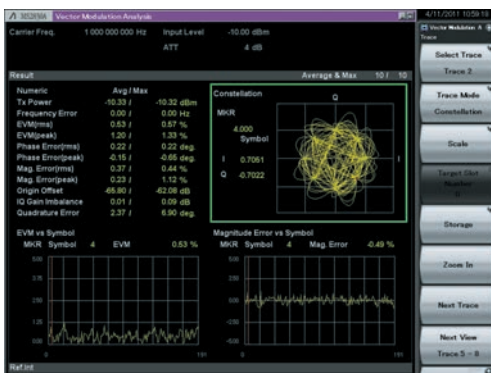

4-pane Screen

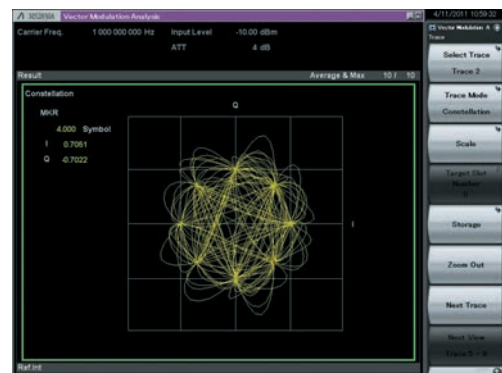

Zoom Screen

MX2690xxA series Measurement Software

Vector Modulation Analysis Software MX269017A (Continued)

MS269xA

MS2840A

MS2830A

Numeric Display

The results of Frequency Error and EVM, etc., can be listed numerically. Selecting Avg/Max displays the average and worst value simultaneously, helping clarify signal dispersion at a glance.



Modulation method: $\pi/4$ DQPSK example

Constellation

This displays the constellation for each modulation method. Interpolation On displays the state transition.

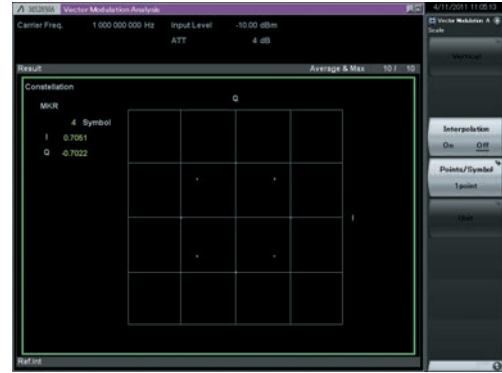

Interpolation: Off

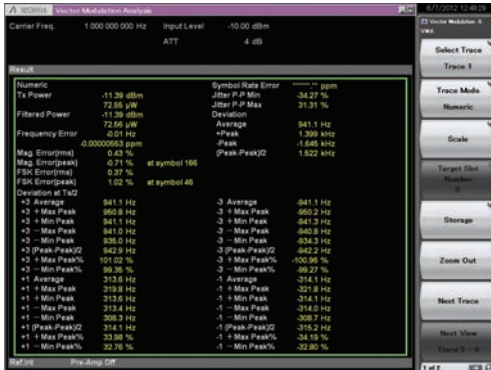

Modulation method: 4FSK example

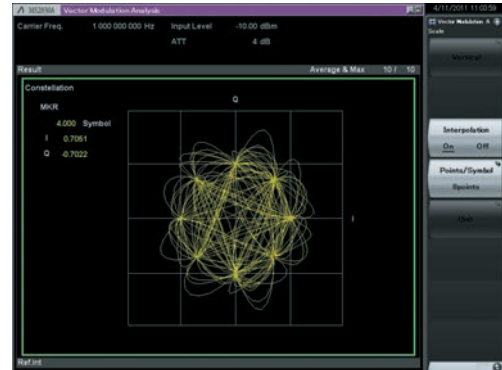

Interpolation: On, Points/Symbol: 8points



Modulation method: O-QPSK example

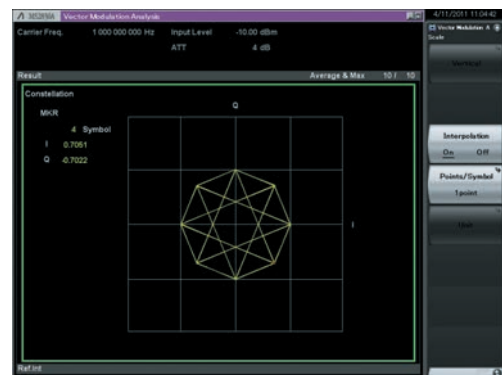

Interpolation: On, Points/Symbol: 1 point

• vs. Symbol

This displays the temporal Symbol variation for each of nine characteristics.

- EVM vs. Symbol
- Magnitude Error vs. Symbol
- Phase Error vs. Symbol
- Frequency vs. Symbol
- I and Q vs. Symbol
- Magnitude vs. Symbol
- Phase vs. Symbol
- FSK Error vs. Symbol
- Fidelity vs. Symbol



EVM vs. Symbol



Phase Error vs. Symbol



I and Q vs. Symbol

• Symbol Table

This displays the symbol decoding result. The display can be switched between binary and hexadecimal. When a synchronized word is detected, it is reverse-displayed.

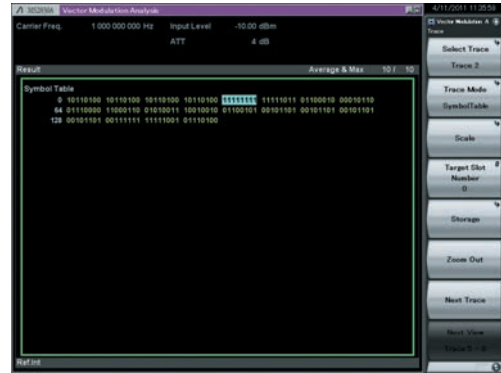

Binary example

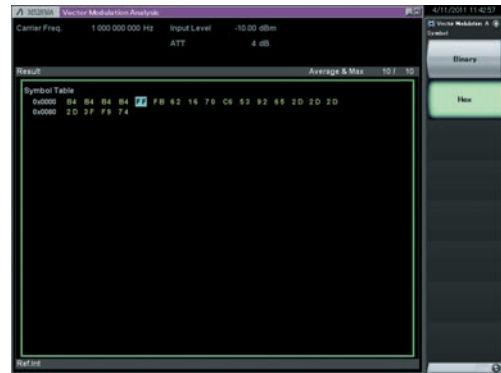

Hexadecimal example

• Eye Diagram

Signal quality can be evaluated visually from the openness of the eye for each symbol at the Eye Diagram screen.

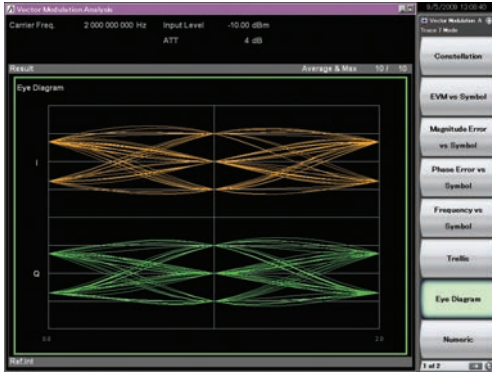

• Graphical Setting Display

Setting is easy using the simple GUI, and the setting parameter Save/Recall function lightens the burden of complex settings.

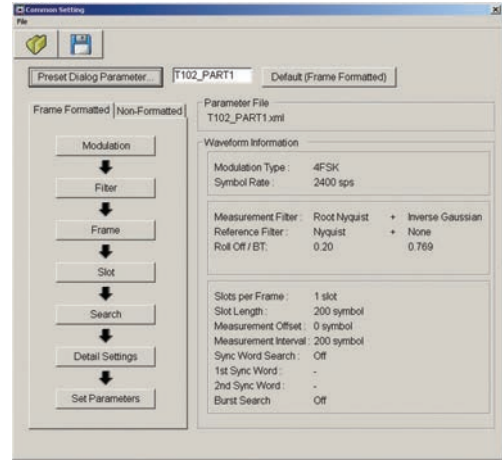

Common Setting

• Trellis

The Trellis screen is used to examine phase transitions of different symbols.

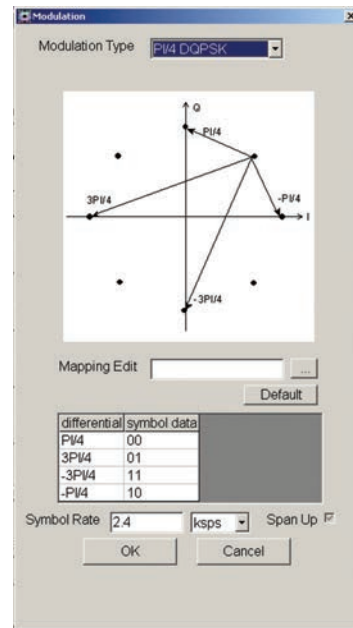
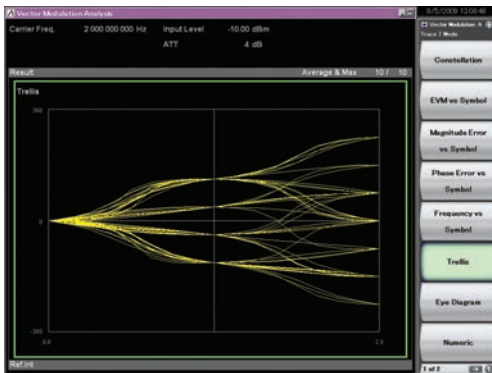

Modulation

• Simple Parameter Setting Function

Simply selecting the standard name at [Preset Dialog Parameter...] Measurement parameters can be set easily for APCO-P25 Phase1/ Phase2, NXDN, TETRA, DMR, dPMR, IEEE 802.15.4/d, RCR STD-39, and ARIB STD-T61, T79, T86, T98, T102.

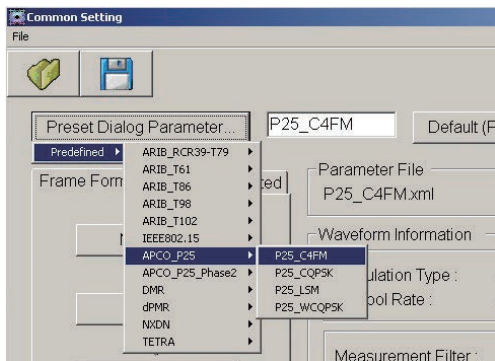

• Power Meter Measurement Function

The power meter measurement can be performed by calling the main-frame. Power meter function can connect a USB power sensor to the main-frame and read the measurement values. Settings of Carrier Frequency, Offset, and Offset Value are automatically reflected on the corresponding parameters.

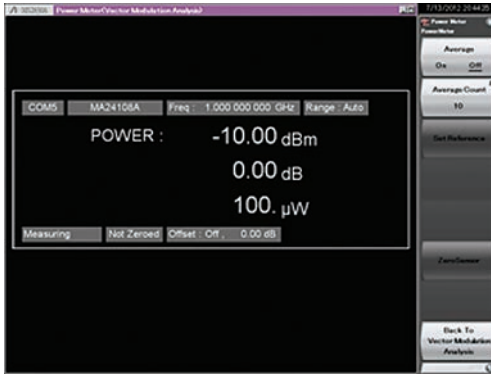

Compatible USB Power Sensors

Model	Frequency Range	Dynamic Range
MA24104A*	600 MHz to 4 GHz	+3 to +51.76 dBm
MA24105A	350 MHz to 4 GHz	+3 to +51.76 dBm
MA24106A	50 MHz to 6 GHz	-40 to +23 dBm
MA24108A	10 MHz to 8 GHz	-40 to +20 dBm
MA24118A	10 MHz to 18 GHz	-40 to +20 dBm
MA24126A	10 MHz to 26 GHz	-40 to +20 dBm

*: MA24104A has been discontinued.

The Analog Measurement Software MX269018A supports measurement of TRx characteristics of analog mobile radio. Installing this software in the MS2840A and MS2830A supports fast and accurate measurement, offering an ideal and efficient evaluation platform for development, production, and maintenance of analog wireless equipment.

The various functions for development, production and maintenance of analog mobile radio are supported

All the TRx performance tests (FM/ΦM/AM) required by analog mobile radio are supported.

■ Supported Signal Analyzer MS2830A Functions

Both RF and AF signal TRx functions can be implemented simultaneously by combining the MS2830A with the analog signal generator and audio analyzer options, supporting all-in-one tests of key analog mobile radio TRx characteristics. All the high-pass, low-pass, and band-pass (weighting) filters as well as de-emphasis functions required for measuring AF signals for each type of analog mobile radio are provided for monitoring demodulated audio signals. The Audio Analyzer option with PTT (Push To Talk) connector controls the analog mobile radio PTT On/Off function.

Table 1. Functions of Analog Measurement Software and Required Configuration (MS2830A)

Analog Measurement Software Function*1			Modulation Method of Target Signal			Required Options (Refer to details of each item in Table 2.)
			FM	ΦM	AM	
Tx Tests	RF Measurements	Carrier Frequency and Carrier Frequency Error <i>RF Frequency</i>	✓	✓	✓	1, 2, 3, 4 are mandatory 1. Signal Analyzer (MS2830A-040/041/043*) 2. Low Phase Noise Performance (MS2830A-066) 3. Analog Measurement Software (MX269018A) 4. USB Audio (A0086B) 5. Commercial loudspeaker *: As shown above, the analog signal generator 7 cannot be installed in the MS2830A-043 because the MS2830A-066 is required.
		Transmit Power <i>RF Power</i>	✓	✓	✓	
		Modulation Measurement <i>Deviation (FM), Radian (ΦM), Depth (AM)</i>	✓	✓	✓	
		Result of Analyzed DCS Code <i>DCS Code</i>	✓	—	—	
	AF Measurements (Demodulation)	Demodulation Frequency <i>AF Frequency</i>	✓	✓	✓	
		Effective Level Value at Demodulation Frequency <i>Level</i>	✓	✓	✓	
		Distortion Ratio of Demodulation Frequency Distortion <i>Distortion, SINAD, THD</i>	✓	✓	✓	
		Time vs. Level, Frequency vs. Level <i>Graph Result</i>	✓	✓	✓	
		Demodulates input RF signals from analog mobile radio and outputs sound from USB Audio connector*2	✓*3	✓	✓	
	AF Output (Audio Generator Function)	Demodulates input RF signals from analog mobile radio and outputs sound from internal speaker, headphone jack and demodulation output connector	✓*3	—	—	
AF Tone, DCS, White Noise (ITU-T Recommendation G.227), DTMF		✓	✓	✓		
PTT (Push To Talk) Control			✓	✓	✓	
Rx Tests	RF Output	Modulation Signal Output (FM, ΦM, AM)	✓	✓	✓	1 + 2 + 3 + 4 +7 Analog Signal Generator (Refer to Table 3.)
		Internal Modulation Signal Source (AF Tone)	✓	✓	✓	
		Internal Modulation Signal Source (DCS)	✓	—	—	
	AF Measurements (Audio Analyzer Function)	Frequency <i>AF Frequency</i>	✓	✓	✓	1 + 2 + 3 + 4 +6 Audio Analyzer (MS2830A-018) +7 Analog Signal Generator (Refer to Table 3.)
		Effective Level Value <i>Level</i>	✓	✓	✓	
		Distortion Ratio <i>SINAD, THD, THD+N</i>	✓	✓	✓	
		Graph (Time vs. Level, Frequency vs. Level) <i>Graph Result</i>	✓	✓	✓	
	PTT (Push To Talk) Control			✓	✓	✓

*1: Spurious can also be measured using the standard spectrum analyzer measurement function.

*2: Voice can be monitored by connecting a commercial loudspeaker using the A0086A or A0086B USB Audio option.

*3: The Wide Band FM measurement mode is not supported.

Table 2. Ordering Information for Analog Measurement Software (MS2830A)

	Name	Model		Note
		New	Retrofit	
Mandatory	3.6 GHz Signal Analyzer	MS2830A-040	—	9 kHz to 3.6 GHz This option cannot be retrofitted.
	6 GHz Signal Analyzer	MS2830A-041	—	9 kHz to 6 GHz This option cannot be retrofitted.
	13.5 GHz Signal Analyzer	MS2830A-043	—	9 kHz to 13.5 GHz This option cannot be retrofitted. The MS2830A-066 and signal generator options cannot be installed simultaneously.
Mandatory	Low Phase Noise Performance	MS2830A-066	—	This option cannot be retrofitted. It improves phase noise performance.
Mandatory	Analog Measurement Software	MX269018A		Retrofit it is supported.
Mandatory	USB Audio	A0086B		Required for output of demodulated audio
Recommended	3.6 GHz Analog Signal Generator	MS2830A-088	MS2830A-188	Frequency setting range: 100 kHz to 3 GHz Required for Rx tests Refer to the selection conditions in Table 3.
	Audio Analyzer	MS2830A-018	MS2830A-118	
	Vector Function Extension for Analog Signal Generator	—	MS2830A-189	Add vector function to MS2830A-088/188
	3.6 GHz Vector Signal Generator	MS2830A-020	MS2830A-120	250 kHz to 3.6 GHz
	6 GHz Vector Signal Generator	MS2830A-021	MS2830A-121	250 kHz to 6 GHz
	Low Power Extension for Vector Signal Generator	MS2830A-022	MS2830A-122	Extends lower output level limit Mandatory for MS2830A-029
	Analog Function Extension for Vector Signal Generator	MS2830A-029	*	Adds analog function to MS2830A-020/021 (Requires MX269018A) Required for Rx tests Refer to the selection conditions in Table 3.

*: Please contact our sales representative

Table 3. Optional Combination Necessary for Mounting Analog Signal Generator (MS2830A)

Option model are decided by the MS2830A which required Analog Signal Generator (SG).

Please note that there is a case where an analog SG function cannot be installed for a part of MS2830A composition.

MS2830A with Installed Analog SG		New MS2830A	When Retrofitting Analog SG in MS2830A		
MS2830A Frequency Option		↓	MS2830A-040/041		MS2830A-043
Installed Vector SG		↓	Not installed	MS2830A-020/021	↓
Supported SG addition	Analog SG	MS2830A-088	MS2830A-188	*1	Cannot be installed
	Analog SG + Vector SG	MS2830A-020 or MS2830A-021 + MS2830A-022 + MS2830A-029	MS2830A-188*2 + MS2830A-189*2	—	

*1: Please contact our sales representative

*2: Can select only 3.6 GHz Vector SG/Analog SG

■ Supported Signal Analyzer MS2840A Functions

Combining the MS2840A with the analog signal generator option provides all-in-one support for tests of TRx characteristics of analog mobile radio. As well as RF measurements including Tx frequency, Tx power, FM deviation, etc., Tx tests can also be used to the demodulation frequency, distortion, etc., of demodulated AF signals. High-pass filters, low-pass filters, band-pass filters (weighting filters), and de-emphasis functions support measurement of demodulated signals for each wireless type. Additionally, at Rx tests, a modulation signal can be output from the analog signal generator and AF tones and DCS codes can also be output using the built-in modulation output function.

However, the audio analyzer option and analog wireless automatic measurement software are not supported.

Table 4. Supported Signal Analyzer MS2840A Frequency Options

Option	Frequency Option	✓: Supported, —: Not supported	
		MS2840A-040 (3.6 GHz) MS2840A-041 (6 GHz)	MS2840A-044 (26.5 GHz) MS2840A-046 (44.5 GHz)
Analog Measurement Software (MX269018A)		✓	✓
Analog Signal Generator (MS2840A-088, 029)		✓	—
Audio Analyzer		—	—

Table 5. Functions of Analog Measurement Software and Required Configuration (MS2840A)

Analog Measurement Software Function*1			Modulation Method of Target Signal			Required Options (Refer to details of each item in Table 6.)
			FM	ΦM	AM	
Tx Tests	RF Measurements	Carrier Frequency and Carrier Frequency Error <i>RF Frequency</i>	✓	✓	✓	1, 2, and 3 are mandatory 1. Signal Analyzer (MS2840A-040/041/044/046) 2. Analog Measurement Software (MX269018A) 3. USB Audio (A0086B) 4. Commercial loudspeaker
		Transmit Power <i>RF Power</i>	✓	✓	✓	
		Modulation Measurement <i>Deviation (FM), Radian (ΦM), Depth (AM)</i>	✓	✓	✓	
		Result of Analyzed DCS Code <i>DCS Code</i>	✓	—	—	
	AF Measurements (Demodulation)	Demodulation Frequency <i>AF Frequency</i>	✓	✓	✓	
		Effective Level Value at Demodulation Frequency <i>Level</i>	✓	✓	✓	
		Distortion Ratio of Demodulation Frequency Distortion <i>Distortion, SINAD, THD</i>	✓	✓	✓	
		Time vs. Level, Frequency vs. Level <i>Graph Result</i>	✓	✓	✓	
		Demodulates input RF signals from analog mobile radio and outputs sound from USB Audio connector*2	✓*3	✓	✓	
	AF Output (Audio Generator Function)	Demodulates input RF signals from analog mobile radio and outputs sound from internal speaker*3, headphone jack*3 and demodulation output connector*3	—	—	—	
AF Tone, DCS, White Noise (ITU-T Recommendation G.227), DTMF		—	—	—		
PTT (Push To Talk) Control			—	—	—	
Rx Tests	RF Output	Modulation Signal Output (FM, ΦM, AM)	✓	✓	✓	Not supported by MS2840A-044/046 1 + 2 + 3 + 5 Analog Signal Generator (Refer to Table 7.)
		Internal Modulation Signal Source (AF Tone)	✓	✓	✓	
		Internal Modulation Signal Source (DCS)	✓	—	—	
	AF Measurements (Audio Analyzer Function)	Frequency <i>AF Frequency</i>	—	—	—	Not supported by MS2840A
		Effective Level Value <i>Level</i>	—	—	—	
		Distortion Ratio <i>SINAD, THD, THD+N</i>	—	—	—	
		Graph (Time vs. Level, Frequency vs. Level) <i>Graph Result</i>	—	—	—	

*1: Spurios can also be measured using the standard spectrum analyzer measurement function.

*2: Voice can be monitored by connecting a commercial loudspeaker using the A0086A or A0086B USB Audio option.

*3: The Wide Band FM measurement mode is not supported.

MX2690xxA series Measurement Software

Analog Measurement Software MX269018A (Continued)

MS2840A

MS2830A

Table 6. Ordering Information for Analog Measurement Software (MS2840A)

This software cannot be installed in the MS2830A 26.5 GHz/43 GHz models, but can be installed in the MS2840A 26.5 GHz/44.5 GHz models. And the MS2830A requires the Low Phase Noise Performance MS2830A-066 but the MS2840A does not require the Low Phase Noise Performance MS2840A-066.

With 3.6 GHz Signal Analyzer (MS2840A-040) or 6 GHz Signal Analyzer (MS2840A-041)

	Name	Model		Note
		New	Retrofit	
Mandatory	3.6 GHz Signal Analyzer	MS2840A-040	—	9 kHz to 3.6 GHz This option cannot be retrofitted.
	6 GHz Signal Analyzer	MS2840A-041	—	9 kHz to 6 GHz This option cannot be retrofitted.
Mandatory	Analog Measurement Software	MX269018A		Frequency range (Tx Tests): 100 kHz to 2.7 GHz (At Wide Band FM measurement: 10 MHz to 2.7 GHz) Retrofit is supported.
Mandatory	USB Audio	A0086B		Required for output of demodulated audio
Recommended	Low Phase Noise Performance	MS2840A-066	MS2840A-166	Improves phase noise performance. This option greatly improves SSB phase noise performance.
	3.6 GHz Analog Signal Generator	MS2840A-088	MS2840A-188	100 kHz to 3 GHz Required for Rx tests Refer to the selection conditions in Table 7.
	Vector Function Extension for Analog Signal Generator	—	MS2840A-189	Add vector function to MS2840A-088/188
	3.6 GHz Vector Signal Generator	MS2840A-020	MS2840A-120	250 kHz to 3.6 GHz
	6 GHz Vector Signal Generator	MS2840A-021	MS2840A-121	250 kHz to 6 GHz
	Low Power Extension for Vector Signal Generator	MS2840A-022	MS2840A-122	Extends lower output level limit Mandatory for MS2840A-029
	Analog Function Extension for Vector Signal Generator	MS2840A-029	MS2840A-129	Adds analog function to MS2840A-020/021 (Requires MX269018A) Required for Rx tests Refer to the selection conditions in Table 7.

With 26.5 GHz Signal Analyzer (MS2840A-044) or 44.5 GHz Signal Analyzer (MS2840A-046)

	Name	Model		Note
		New	Retrofit	
Mandatory	26.5 GHz Signal Analyzer	MS2840A-044	—	9 kHz to 22.5 GHz This option cannot be retrofitted.
	44.5 GHz Signal Analyzer	MS2840A-046	—	9 kHz to 44.5 GHz This option cannot be retrofitted.
Mandatory	Analog Measurement Software	MX269018A		Frequency range (Tx Tests): 100 kHz to 2.7 GHz (At Wide Band FM measurement: 10 MHz to 2.7 GHz) Retrofit is supported.
Mandatory	USB Audio	A0086B		Required for output of demodulated audio

Table 7. Optional Combination Necessary for Mounting Analog Signal Generator (MS2840A)

Option model are decided by the MS2840A which required Analog Signal Generator (SG).

MS2840A with Installed Analog SG		New MS2840A	When Retrofitting Analog SG in MS2840A	
MS2840A Frequency Option		↓	MS2840A-040/041	
Installed Vector SG		↓	Not installed	MS2840A-020/021
Supported SG addition	Analog SG	MS2840A-088	MS2840A-188	MS2840A-129 + MS2840A-122*2
	Analog SG + Vector SG	MS2840A-020 or 021 + MS2840A-022 + MS2840A-029	MS2840A-188*1 + MS2840A-189*1	—

*1: Can select only 3.6 GHz Vector SG/Analog SG

*2: Unnecessary when MS2840A-022 already installed

MX2690xxA series Measurement Software

Analog Measurement Software MX269018A (Continued)

MS2840A

MS2830A

Specifications

The specification is the value after 30-minute warm-up at a constant ambient temperature.

The specifications are defined under the following condition unless otherwise specified.

Attenuator mode: Mechanical Attenuator Only, The correct level is set for the input signal.

The Tx measurement specifications apply to the MS2840A, and the MS2830A with built-in MS2830A-062/066 Low Phase Noise Performance Option.

Signal Analyzer		MS2840A	MS2830A	
Tx Measurements		No Audio Analyzer option	Without MS2830A-018/118 Audio Analyzer Option	With MS2830A-018/118 Audio Analyzer Option
Common Specification	Target Signal	FM, Φ M, AM signal		
	Frequency Range	100 kHz to 2700 MHz At Wide Band FM measurement: 10 MHz to 2700 MHz		
	Level Range	-15 to +30 dBm (Preamp Off, or Preamp not installed) -25 to +10 dBm (Preamp On)		
	Carrier Frequency Accuracy	At 18° to 28°C, after calibration \pm (Accuracy of reference frequency \times Carrier frequency + 1) Hz		
FM Measurement	Frequency Deviation	FM: 0 < Frequency Deviation \leq 20 kHz, 20 kHz < Frequency Deviation \leq 40 kHz (nom.) Wide Band FM: 0 < Frequency Deviation \leq 20 kHz, 20 kHz < Frequency Deviation \leq 1 MHz (nom.)		
	Demodulation Frequency Range	20 Hz to 20 kHz		
	Frequency Deviation Accuracy	1% of indicated value \pm Residual FM		
	Residual FM	3.35 Hz rms, S/N: >50 dB (1.5 kHz Deviation, Demodulation Band: 0.3 kHz to 3 kHz)		
	Demodulation Distortion	0.3% (Demodulation Frequency: 1 kHz, Frequency Deviation: 5 kHz, Demodulation Band: 0.3 kHz to 3 kHz)		
	DCS Measurement Function	Digital Code Squelch demodulated result display		
Φ M Measurement	Φ M Deviation	0 to (20 kHz/Demodulation Frequency [Hz]) rad		
	Demodulation Frequency Range	20 Hz to 20 kHz		
	Φ M Deviation Accuracy	1% of indicated value \pm Residual Φ M		
	Residual Φ M	0.01 rad rms (Demodulation Band: 0.3 kHz to 3 kHz)		
	Demodulation Distortion	1% (Demodulation Band: 0.3 kHz to 3 kHz)		
AM Measurement	AM	0 to 98%		
	Demodulation Frequency Range	20 Hz to 20 kHz		
	AM Accuracy	1% of indicated value \pm Residual AM		
	Residual AM	0.3% (Demodulation Band: 0.3 kHz to 3 kHz)		
	Demodulation Distortion	0.3% (Demodulation Band: 0.3 kHz to 3 kHz)		
Filter	Low Pass	300 Hz, 3, 15, 20 kHz		
	High Pass	50, 300, 400 Hz, 30 kHz		
	Band Pass (Weighting filter)	CCITT, C-Message, CCIR 468, CCIR-ARM, A-Weighting		
	De-emphasis	25, 50, 75, 500, 750 μ s		
Amplitude Measurement	Transmit Power Accuracy	At 18° to 28°C, after calibration, Input attenuator: \geq 10 dB, Input signal in measurement level range and less than Input level, Preamp Off, or Preamp not installed \pm 0.5 dB Transmit Power Accuracy based on MS2840A and MS2830A main frame Absolute Amplitude Accuracy		
Audio Monitor (Demodulation Output)		Outputs demodulated signal to USB Audio equipment connected to MS2840A/MS2830A USB terminal (Wide Band FM measurement not supported)		FM/ Φ M/AM: Output demodulated signal to USB audio equipment connected to MS2830A USB terminal (Wide Band FM measurements not supported) FM: Internal speaker, headphone jack or demodulation output connector (Wide Band FM measurements not supported)

MX2690xxA series Measurement Software

Analog Measurement Software MX269018A (Continued)

MS2840A

MS2830A

Signal Analyzer		MS2840A	MS2830A
Rx Measurements		No Audio Analyzer option	Without MS2830A-018/118 Audio Analyzer Option
		With MS2830A-018/118 Audio Analyzer Option	
		This function is enabled either when the MS2830A/MS2840A-088 3.6 GHz Analog Signal Generator is installed, or when the MS2830A/MS2840A-020/021 Vector Signal Generator and MS2830A/MS2840A-022 Low Power Extension for Vector Signal Generator and MS2830A/MS2840A-029 Analog Function Extension for Vector Signal Generator are installed	
RF Signal Output		The performance specifications are for the MS2830A-088 or MS2830A-020/021 when the MS2830A-029 is installed	
	Frequency Setting Range	100 kHz to 3000 MHz	
	Frequency Setting Resolution	1 Hz	
	Output Setting Level	-127 to +15 dBm (Rx frequency > 25 MHz) -127 to -3 dBm (Rx frequency ≤ 25 MHz)	
FM	Frequency Deviation Setting Range	0 to 100 kHz	
	Frequency Deviation Setting Resolution	0.1 Hz	
	Frequency Deviation Accuracy	±1% of set value (excludes Residual FM)	
	Internal Modulation Signal Source	AF Tone Source × 2 Digital Code Squelch Signal Generator	AF Tone Source × 3 Digital Code Squelch Signal Generator
	Internal Modulation Frequency Range	Tone Frequency: 20 Hz to 40 kHz	
	Internal Modulation Frequency Resolution	0.1 Hz, Setting value ±3 Hz on use of Digital Code Squelch signal	
	DCS Code Setting Range	DCS Code: 000 to 777 (octal, 3-digit)	
ΦM	Phase Deviation Setting Range	Settable with the range of 0 to 50.0 rad. (internal modulation frequency × phase deviation) < 100 kHz	
	Phase Deviation Setting Resolution	0.01 rad.	
	Phase Deviation Accuracy	±1% of set value (excludes Residual ΦM)	
	Internal Modulation Signal Source	AF Tone Source × 2	AF Tone Source × 3
	Internal Modulation Frequency Range	Tone Frequency: 20 Hz to 40 kHz	
AM	Internal Modulation Frequency Resolution	0.1 Hz	
	Modulation Setting Range	0 to 100%	
	Modulation Setting Resolution	1%	
	Modulation Accuracy	±1% of set value (excludes Residual AM)	
	Internal Modulation Signal Source	AF Tone Source × 2	AF Tone Source × 3
	Internal Modulation Frequency Range	Tone Frequency: 20 Hz to 40 kHz	
	Internal Modulation Frequency Resolution	0.1 Hz	

Analog Signal Generator Option		MS2840A-029/129/088/188	MS2830A-029/088/188
Max. Reverse Input		0 Vdc (max.) +18 dBm (<20 MHz), +30 dBm (≥20 MHz)	
Function/Performance		The following specifications (see MS2840A catalog) are added to the specifications when the MS2840A-020/021 and MS2840A-022 are installed	The following specifications (see MS2830A catalog) are added to the specifications when the MS2830A-020/021 and MS2830A-022 are installed
	Frequency Setting Range	100 kHz to 3000 MHz	100 kHz to 3000 MHz
	Frequency Setting Resolution	1 Hz	
	Output Setting Level	-127 to +15 dBm (Rx frequency > 25 MHz) -127 to -3 dBm (Rx frequency ≤ 25 MHz)	
Output Level Accuracy		18° to 28°C, CW MS2830A-029/088/188 MS2840A-029/129/088/188	
			Output level [p] (dBm)
		±3.0 dB (typ., 100 kHz ≤ f < 250 kHz)	-110 ≤ p ≤ -3
		±1.0 dB (typ., 250 kHz ≤ f ≤ 25 MHz)	-110 ≤ p ≤ -3
		±1.0 dB (typ., 25 MHz < f < 100 MHz)	-110 ≤ p ≤ +4
		±0.5 dB (typ., 100 MHz ≤ f < 375 GHz)	-110 ≤ p ≤ +4
		±0.5 dB (375 MHz ≤ f ≤ 3 GHz)	-110 ≤ p ≤ +4
	±1.0 dB (100 MHz ≤ f ≤ 3 GHz)	-120 ≤ p < -110	
	±1.0 dB (typ., 100 MHz ≤ f ≤ 3 GHz)	-127 ≤ p < -120	
Arbitrary Signal Generator		Available when the MS2830A-020, 021 or 189 (Vector Signal Generator) is installed	

Audio Analyzer Option		MS2830A-018/118		
Audio Analyzer Function		The specifications for single tone measurement are listed below		
Measurement Function		Amplitude, Frequency, THD, THD+N, SINAD		
Connection Type		Balanced: 1/4-inch phone jack (3-pole, Φ 6.3 mm) Unbalanced: BNC-J		
Impedance		Balanced: 200 k Ω (AC coupled, nom.) Unbalanced: 100 k Ω (AC coupled, nom.)		
Frequency Measurement Range		20 Hz to 50 kHz		
Level Measurement Range		1 mV rms to 25 V rms (30 V rms, max.)		
Input Range Setting		50 mV peak, 500 mV peak, 5 V peak, 50 V peak		
Level Accuracy		18° to 28°C ± 0.4 dB (20 Hz \leq f \leq 25 kHz) ± 3.0 dB (25 kHz < f \leq 50 kHz)		
THD + N (Total Harmonic Distortion + Noise)		At 1 kHz, 1.4 V rms, Band: 20 Hz to 20 kHz, Range: 5 Vp-p, 18° to 28°C <-60 dB <-80 dB (nom.)		
Audio Filter	Low-pass	Off, 3, 15, 20, 30, 50 kHz		
	High-pass	Off, 20, 50, 100, 300, 400 Hz, 30 kHz		
	Bandpass (Weighting filter)	Off, CCITT, C-Message, CCIR468, CCIR-ARM, A-Weighting		
Audio Generator Function		The specifications for all single-tone measurements except White Noise (through ITU-T G.227 filter)		
Connection Type		Balanced: 1/4-inch phone jack (3-pole, Φ 6.3 mm) Unbalanced: BNC-J		
Interface		Balanced: 100 Ω /600 Ω (AC coupled, nom.) Unbalanced: 50 Ω /600 Ω (AC coupled, nom.)		
Output Waveform		Single tone, multi-tone: Tone \times 3, DCS, White noise (ITU-T G.227), DTMF		
Guaranteed Frequency Range		20 Hz to 25 kHz		
Frequency Setting Range		10 Hz to 50 kHz		
Frequency Resolution		0.01 Hz		
Output Level Range		Using Sub Supply/Audio Revision 2*1		
		Single tone		
		Open circuit voltage (≥ 100 k Ω termination)	Balanced	Off, 1 mV rms to 12.4 V rms
			Unbalanced	Off, 1 mV rms to 6.2 V rms
		600 Ω termination*	Balanced	Off, -63 dBm (equivalent to 0.5 mV rms) to +18 dBm (equivalent to 6.2 V rms)
			Unbalanced	Off, -63 dBm (equivalent to 0.5 mV rms) to +12 dBm (equivalent to 3.1 V rms)
White noise (through ITU-T G.227 filter)				
Open circuit voltage (≥ 100 k Ω termination)	Balanced	Off, 1.545 mV rms to 3.083 V rms (nom.)		
	Unbalanced	Off, 1.545 mV rms to 1.545 V rms (nom.)		
600 Ω termination*	Balanced	Off, -60 dBm (equivalent to 0.774 mV rms) to +6 dBm (equivalent to 1.545 V rms) (nom.)		
	Unbalanced	Off, -60 dBm (equivalent to 0.774 mV rms) to 0 dBm (equivalent to 0.774 V rms) (nom.)		
Output Level Resolution		*1: Output Impedance = 600 Ω , and Output Impedance Reference = 600 Ω Single tone: 1 mV (350 mV rms < Output Level \leq 6.2 V rms) 100 μ V (35 mV rms < Output Level \leq 350 mV rms) 10 μ V (Output Level \leq 35 mV rms) White noise (through ITU-T G.227 filter): 0.01 dB (nom.)		
Level Accuracy		Single tone: ± 0.3 dB (1 kHz, 100 k Ω termination, 18° to 28°C) White noise (through ITU-T G.227 filter): ± 3 dB (nom.)		
Maximum Output Current		100 mA (nominal, no short circuit)		
THD + N (Total Harmonic Distortion + Noise)		At 1 kHz, 0.7 V rms, Band: 20 Hz to 25 kHz, 100 k Ω termination, 18° to 28°C <-60 dB <-80 dB (nom.)		
Other Function				
Demodulation Output (FM only)*2	Connector Type	BNC-J		
	Demodulation Output Level	-10 dBm ± 2 dB (Frequency deviation: 3.5 kHz, 600 Ω)		
	Demodulation Output Impedance	600 Ω		
	Sound Monitor	Internal speaker or 3.5 mm phone jack (2-pole, monaural)		
Crosstalk		Crosstalk from Audio Generator to Audio Analyzer >80 dB		
PTT (Push To Talk) Control		Banana jack (Φ 4.0 mm, 30 V, 500 mA max.)		
General Input/Output (Audio Function)		Connector: D-Sub 15 pin (jack) Function: Open Collector \times 1 (5 V, 100 mA max.), TTL Output \times 2, TTL Input \times 2		

*1: Sub Supply/Audio Revision is the MS2830A-018/118 printed-circuit board version.

<Sub Supply/Audio Revision Confirmation Method>

(1) MS2830A units with Sub Supply/Audio Revision 2 have a sticker marked 'A1' next to the main-frame serial number.

(2) The MS2830A Sub Supply/Audio Revision can be confirmed as follows:

Press [System Config] \rightarrow [F5] System Information \rightarrow [F4] Board Revision View to list the Board Revisions; check the displayed Sub Supply/Audio Revision number. (It may be either 1 or 2.)

*2: For Tx test of analog mobile radio. Wide Band FM measurements not supported.

Tx Tests

• Inputting AF Signal to analog mobile radio and Measuring Characteristics of RF Signal Output from Radio

Combining the MS2830A with the audio analyzer option supports tuning of the AF signal output (AF signal input to the analog mobile radio) and testing of the radio RF transmission characteristics by monitoring at one screen.

As well as outputting the AF signal simultaneously as up to three tones, tone + DCS, white noise (ITU-T G.227) and DTMF signals can be output too. At the analog mobile radio RF Tx characteristics test, the FM/ΦM/AM frequency, power, modulation degree, demodulated AF signal frequency, level, distortion, as well as time vs. level, and frequency vs. level graphs are displayed simultaneously. At FM modulation, the DCS (Digital Code Squelch) Code analysis is displayed as well. Moreover, frequency deviation measurement can be extended up to 1 MHz in the Wide FM measurement mode (usually up to 40 kHz in the normal FM measurement mode).

Various AF filters can be set according to the analog mobile radio when analyzing demodulated AF signals. As well as the common high-pass and low-pass filter settings, there are five CCITT, C-Message, CCIR 468, CCIR-ARM, and A-Weighting bandpass filters (weighting filters) plus five types of De-emphasis setting (25, 50, 75, 500, and 750 μs).

Other application software such as a spectrum analyzer can be used simultaneously at AF signal output. For example, in addition to outputting white noise (ITU-T G.227), both spurious and occupied bandwidth (OBW) measurements can be made using the spectrum analyzer display.

The Audio Analyzer option has a PTT (Push To Talk) connector for On/Off control of the analog mobile radio PTT.

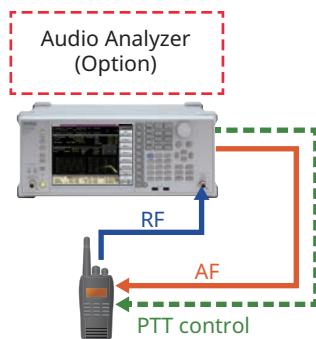

Tx Characteristics Test Setup

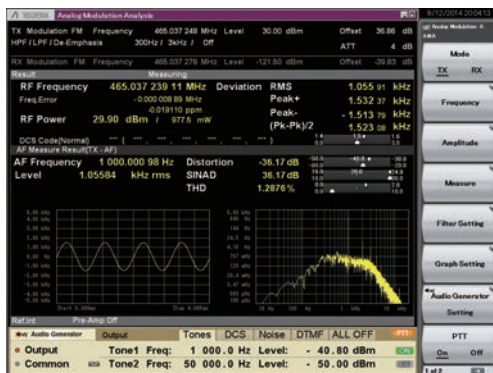

Example of AF Signal Output and FM Modulation Signal Measurement Screen (with Audio Analyzer Option)

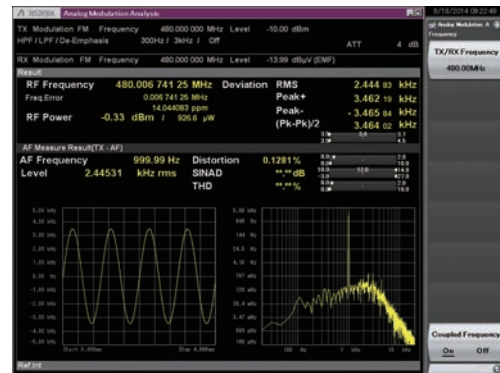

Example of FM Modulation Signal Measurement Screen (without Audio Analyzer Option)

Rx Tests

• Outputting FM/ΦM/AM Signal to analog mobile radio and Measuring AF Signal Demodulated by Measuring Instrument

Combining the MS2830A with the analog signal generator and audio analyzer options supports tuning of the RF signal output (RF signal input to the analog mobile radio) and testing of the AF signal characteristics output from the radio by monitoring on one screen. The RF signal output from the analog signal generator supports FM/ΦM/AM modulations, and in addition to outputting up to three AF tones from the internal modulation signal source simultaneously, can also output signals created as DCS (FM only) and Wave audio format files.

At measurement of AF signals using the Audio Analyzer option, not only the frequency, level, and distortion (SINAD measurement, etc.), but also graphs of the time vs. level and frequency vs. level can be displayed simultaneously. The distortion display can either be as a numeric display or as a graph for easy SINAD tuning at the Rx sensitivity test.

As well as high-pass and low-pass filter settings for AF filters, up to five types of CCITT, C-Message, CCIR 468, CCIR-ARM, and A-Weighting bandpass filters (weighting filters) can be set.

<About Internal Modulation Signal Source>

Up to three*1 AF tone signal sources and one DCS signal source are provided.

For example, the analog mobile radio operation confirmation test can use any of the following combinations:

- AF + AF + AF
(1 kHz audio signal + Tone squelch signal + Audio signal of any frequency)
- AF + AF + DCS
(1 kHz audio signal + Audio signal of any frequency + DCS signal)
- AF (Wave audio format)*2

*1: Two when Audio Analyzer option not installed

*2: Output of a Wave audio format signal can also be set with the internal modulation signal source. An RF signal, such as DTMF (Dual Tone Multiple Frequency), can be output.

The following limitations apply:

- Linear PCM file
(It is not possible to support ADPCM and the compressed format for enhanced PCM.)
- The reproduction is monaural or stereo.
(Multi-channel is not supported and the L-Channel is used to reproduce stereo.)
- The sampling quantization bit rate is 8 or 16 bits (full-scale at modulation and modulation depth set)
- Data replay of 10 s or less
- The sampling frequency is either 44.1, 48, or 96 kHz.

Note: Sometimes, the Wave audio format file may not be loaded even if it meets the above specifications.

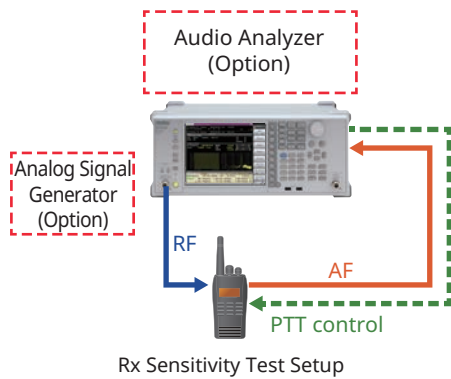

Using Meter Displays

Useful Meter Displays for Rx Sensitivity Test and Frequency Deviation Measurements

Results can be displayed both as numeric and convenient meter values for confirming and tuning SINAD, THD, Distortion, and frequency deviation measurements. Meters are split into upper and lower sections; setting a narrow range at the upper meter and a wider range at the lower meter makes it possible to clearly understand the range for tuning at the lower meter, as well as perform fine adjustments in a narrow range at the upper meter when approaching the required value. Using these meters offers a more intuitive adjustment method than directly reading numeric values that fluctuate when adjusting SINAD at Rx sensitivity tests and frequency deviation at Tx tests (FM only).



Example of RF Signal Output and AF Signal Measurement Screen (with Analog Signal Generator and Audio Analyzer Options)



SINAD Meter

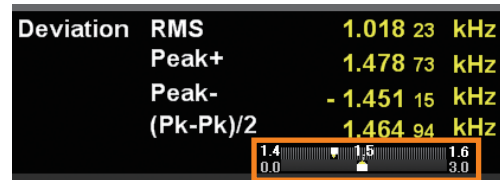

Frequency Deviation Meter (FM only)

Pass/Fail Displays

Pass/Fail evaluations are displayed at all meters by setting the values for the pass range and number of measurement times.

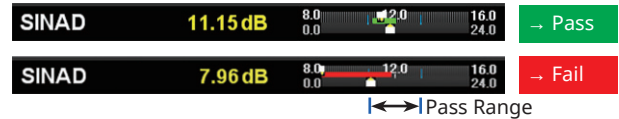

Example of RF Output Measurement Screen (with Analog Signal Generator)

Demodulated Voice Output

Demodulating RF Signal from analog mobile radio to Output Audio Signal

The RF signal from the analog mobile radio is demodulated and the audio signal is output from the USB connector. The audio signal output from the USB Audio option can be monitored using a commercial loudspeaker.

Additionally, when the Audio Analyzer option is installed, the audio signal can be monitored either at the internal speaker, the headphone jack or the demodulation output connector.*

*: Only supports FM and Wide FM measurement mode not supported.

MX2690xxA series Measurement Software

LTE Downlink Measurement Software MX269020A
LTE-Advanced FDD Downlink Measurement Software MX269020A-001
LTE TDD Downlink Measurement Software MX269022A
LTE-Advanced TDD Downlink Measurement Software MX269022A-001

MS269xA

MS2830A

The LTE Downlink Measurement Software MX269020A and LTE TDD Downlink Measurement Software MX269022A support measurement of RF characteristics of 3GPP Release 8 LTE (Long Term Evolution) downlink signals.

The LTE-Advanced FDD Downlink Measurement Software MX269020A-001*1 and LTE-Advanced TDD Downlink Measurement Software MX269022A-001*2 support measurement of RF characteristics of 3GPP Release 10 LTE-Advanced downlink signals.

*1: Requires MX269020A

*2: Requires MX269022A

The MS269020A and the MS269020A-001 support FDD (Frequency Division Duplex) measurement systems while the MX269022A and the MX269022A-001 support TDD (Time Division Duplex) systems.

Installing these software applications in the MS269xA or MS2830A signal analyzers offers fast and accurate measurements for improving the quality and efficiency of 3GPP LTE base station and device component development and manufacturing.

Features

■ Support Testing of 3GPP TS 36.141 Release 8 and Release 10 Downlink RF Characteristics

■ Easy Setting of Measurement Conditions

- At prototype signal measurement, measurement is performed simply by specifying the parameter test model.
- Synchronization to the input signal is performed automatically using a Synchronization Signal or Reference Signal.

■ Versatile Analysis Results Formats and Graphs

- Full Output Power, Frequency Error, and EVM
- Power and EVM for each Physical channel
- Both sub-carrier and symbol EVM and I/Q constellation displays
- Power, EVM and I/Q constellation displays for each RB
- Display of EVM and PHY channel type for each resource element
- Spectrum flatness/graph: Amplitude, Phase and Group Delay frequency characteristics

■ MIMO Summary Function: Measures Timing Difference between up to 4 MIMO Tx Signal Antennas

■ Batch Measurement Function: Batch measures and lists displays multiple items such as modulation accuracy and power spectrum

■ Replay Function for Troubleshooting Faults

■ Supports LTE-Advanced Carrier Aggregation Signal Measurements (requires installed LTE-Advanced measurement option)

- Multi-band and multi-carrier measurements
 - In-band continuous carrier batch measurement
 - Inter-band discontinuous carrier measurement as one sequence
- Adjacent channel leakage power, spurious and continuous carrier occupied bandwidth measurements for each band

The LTE-Advanced Carrier Aggregation measurement range varies as follows, depending on the Analysis Bandwidth Extension option configuration.

Main frame	Analysis Bandwidth Extension Option	Maximum Analysis Bandwidth (In-band carrier aggregation range)	Maximum Number of Band	Maximum Number of Component Carrier
MS269xA	MS269xA-078 installed	125 MHz	3	5
	MS269xA-077 installed	31.25 MHz	3	5
	Standard	31.25 MHz	3	5
MS2830A	MS2830A-078 installed	125 MHz	1	5
	MS2830A-077 installed	31.25 MHz	3	5
	MS2830A-005/009 installed	31.25 MHz	3	5

■ Measurement Items

- Frequency Error
- Output Power
- RSTP (RS TX power)
- OSTP (OFDM Symbol TX power)
- EVM (Peak/RMS)
- EVM of each Physical Channel: RS/P-SS/S-SS/PBCH/PCFICH/PHICH/PDSCH
- Origin Offset
- Timing Offset (External Trigger)
- MIMO Summary: Frequency Error, Power, Timing Offset, EVM based on RS of each antenna

■ Graphical Display

- Constellation
- EVM vs. Subcarrier
- EVM vs. Symbol
- Spectral Flatness
- Power vs. Resource Block
- EVM vs. Resource Block
- Resource Element (RE) Map
- Power vs. Time (only MX269022A)

MX2690xxA series Measurement Software

LTE Downlink Measurement Software MX269020A
 LTE-Advanced FDD Downlink Measurement Software MX269020A-001
 LTE TDD Downlink Measurement Software MX269022A
 LTE-Advanced TDD Downlink Measurement Software MX269022A-001 (Continued)

MS269xA

MS2830A

Measurement Functions

• Easy Measurement of Test Model Signals

Test model signals defined in 3GPP TS 36.141 as test patterns for BTS Tx tests are easily measured by selecting the test model name.



Easy measurement by selecting test model name

• Spectral Flatness

This displays a graph of amplitude, amplitude difference, phase, and group delay for each subcarrier for all symbols in a specified measurement segment.

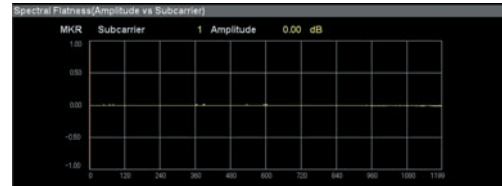

• Frequency Error/Transmit Power/EVM

This displays the frequency error, transmit power and EVM of all subcarriers in a specified measurement segment as a constellation. When averaging is performed, the maximum and mean values are displayed simultaneously.

In addition, the "Auto mode" automatically evaluates the modulation scheme of the input signal to support measurement of DL signals including different modulation schemes for each release block.

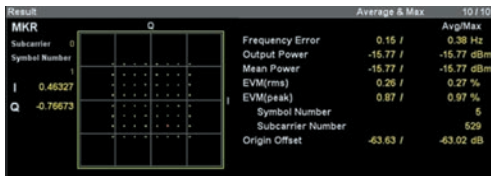

• EVM vs. Subcarrier

This displays a graph of the vector errors for each subcarrier for a specified symbol or for all symbols in a specified segment. Simultaneous display of mean (rms) and peak values.

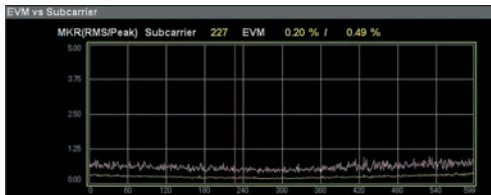

• EVM vs. Symbol

This displays a graph of the vector errors for each symbol for a specified subcarrier or for all subcarriers. Simultaneous display of mean (rms) and peak values.

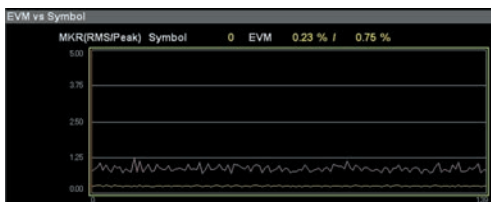

• Summary Display

This displays a list of various information, such as EVM for each channel (PDSCH, PUSCH, PDCCH, RS, SS, PBCH) and the power of each slot.

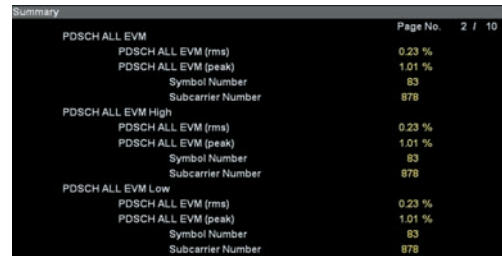

PDSCH EVM Display

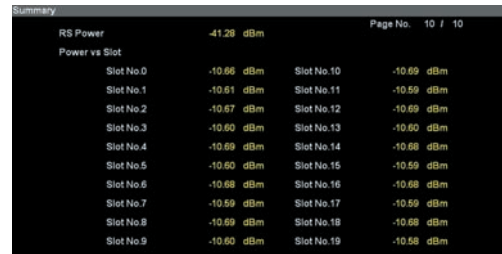

Power vs. Slot

MX2690xxA series Measurement Software

LTE Downlink Measurement Software MX269020A
 LTE-Advanced FDD Downlink Measurement Software MX269020A-001
 LTE TDD Downlink Measurement Software MX269022A
 LTE-Advanced TDD Downlink Measurement Software MX269022A-001 (Continued)

MS269xA MS2830A

Power vs. Resource Block

This displays the power of each resource block in a specified subframe or specified subframe segment. Power boosting over each resource block can be checked easily by visual monitoring of the power distribution. Moreover, simultaneous display of the constellation for a specified resource block makes troubleshooting easy.

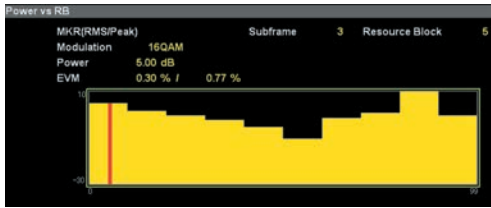

Specified Subframe

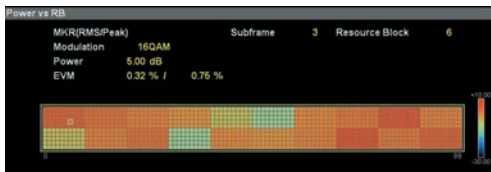

Power Display for Each Resource Block



Constellation for Specified Resource Block

EVM vs. Resource Block

This displays a graph of the EVM distribution for each resource block in a specified subframe segment, making it easy to check resource-block dependent EVM deterioration.

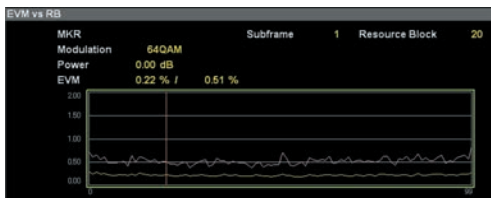

Test Model Summary Display

This displays the analysis results for the signal types set at Test Model.

- RS boosting for each subframe
- EPRE for each channel for each subframe
- PDSCH EPRE for each modulation method for each subframe

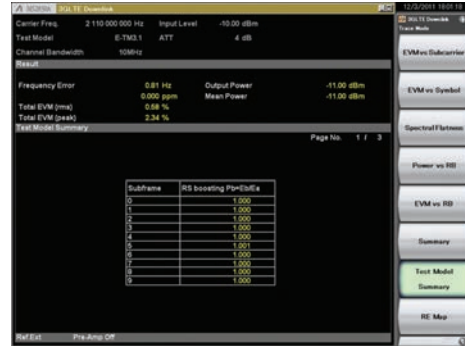

Test Model Summary

MIMO Summary Display

The results for each antenna port are displayed when measuring MIMO. The results are displayed for the number of antenna signals specified at Number of Antenna Ports.

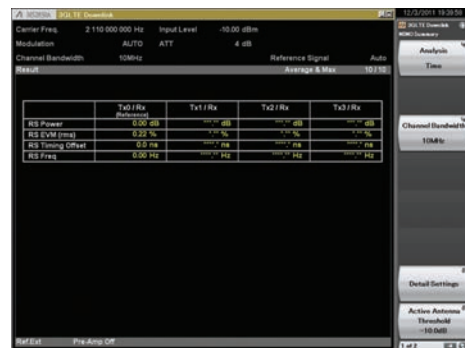

MX2690xxA series Measurement Software

LTE Downlink Measurement Software MX269020A
LTE-Advanced FDD Downlink Measurement Software MX269020A-001
LTE TDD Downlink Measurement Software MX269022A
LTE-Advanced TDD Downlink Measurement Software MX269022A-001 (Continued)

MS269xA **MS2830A**

• **Power vs. Time Function (MX269022A and MS269xA)**

Following numeric result is displayed in the upper part of the screen and displays time variation of signal in 1 Frame section in the lower part of screen.

- Off Power
- On Power
- Transient Period
- Power at Mask Edge
- Mask Judge

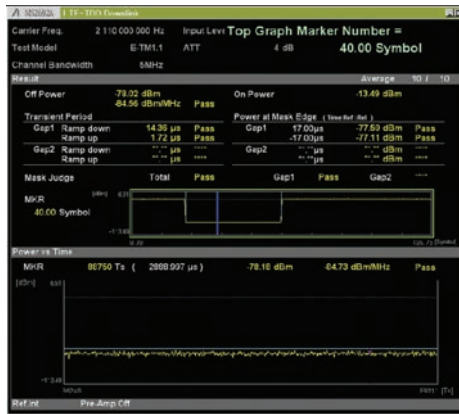

• **Replay Function for Troubleshooting Faults**

Up to 200 frames of LTE signals can be captured as a file for replay by the LTE measurement software to perform analyses such as EVM measurement.*

*: Batch measurement is not supported when the MX269020A-001 is installed.

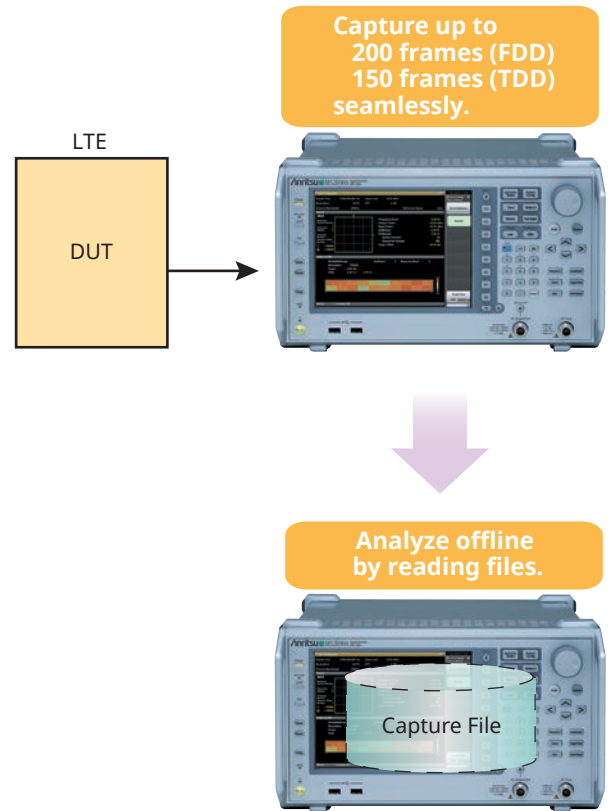

• **Batch Measurement Function**

This function supports batch measurement and list display of the modulation accuracy and Tx power spectrum to shorten the measurement time and comprehensively check the measurement results. When the MS269020A-001 LTE-Advanced FDD Downlink Measurement Software and MX269022A-001 LTE-Advanced TDD Downlink Measurement Software are installed, multiple bands and multiple carriers can be measured at the batch-measurement function screen*.

*: If the LTE-Advanced option is not installed, measurement is limited to only one carrier.

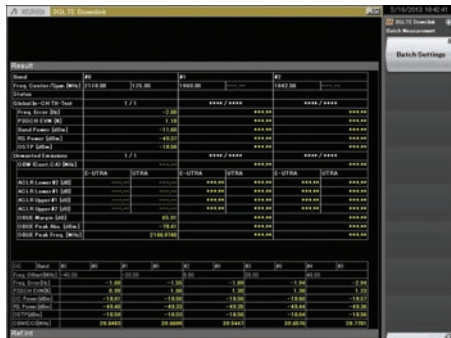

Batch Measurement Screen
 (Measurement example for in-band 5 continuous carriers)

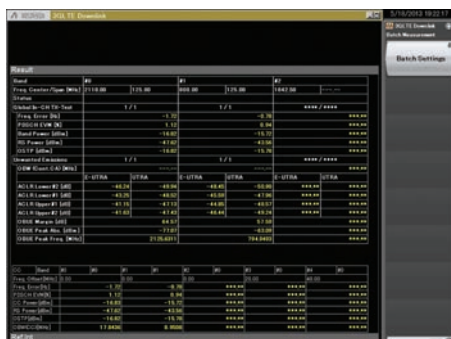

Batch Measurement Screen
 (Measurement example for carriers in 2 bands)

Example of R&D use

- Save data for comparing each DUT test version
- Supports comparison of retrofitting improvement effects

Example of production line use

- Save delivery inspection data
- Supports rechecking of performance data for troubleshooting post-delivery faults

MX2690xxA series Measurement Software

LTE Downlink Measurement Software MX269020A

MS269xA

MS2830A

LTE-Advanced FDD Downlink Measurement Software MX269020A-001

LTE TDD Downlink Measurement Software MX269022A

LTE-Advanced TDD Downlink Measurement Software MX269022A-001 (Continued)

Specifications

The specification is the value after 30-minute warm-up at a constant ambient temperature.

The specifications are defined under the following condition unless otherwise specified.

Attenuator mode: Mechanical Attenuator Only (MS2830A only)

LTE Downlink Measurement Software MX269020A, LTE-Advanced FDD Downlink Measurement Software MX269020A-001

	Signal Analyzer	MS269xA	MS2830A	
Common Specifications	Channel Bandwidth	1.4, 3, 5, 10, 15, 20 MHz		
	Target Signals	Downlink		
	Capture Time	Auto: 1 Frame Manual: 1 to 200 Frame		
Modulation/ Frequency Measurement	Measurement Frequency Range	600 MHz to 4000 MHz	600 MHz to 4000 MHz (MS2830A-041/043/044/045) 600 MHz to 3600 MHz (MS2830A-040)	
	Measurement Level Range	-15 to +30 dBm (Preamp Off, or Preamp not installed) -15 to +10 dBm (Preamp On)		
	Carrier Frequency Measurement Accuracy	After CAL execution at 18° to 28°C For a signal of EVM = 1% For Measurement Interval = 10 Subframe		
		± (Accuracy of reference frequency × Carrier frequency + 3 Hz) (Excluding the Batch Measurement when MS269xA-004 is installed)	± (Accuracy of reference frequency × Carrier frequency + 3.5 Hz) (When the center frequency is from 600 MHz to 2700 MHz and MS2830A-078 is not installed) ± (Accuracy of reference frequency × Carrier frequency + 8.0 Hz) (When the center frequency is from 2700 MHz to 4000 MHz and MS2830A-078 is not installed) ± (Accuracy of reference frequency × Carrier frequency + 4.0 Hz) (In the CC of the center frequency when the center frequency is from 600 MHz to 2700 MHz and MS2830A-078 is installed) (At the input level of -4 dBm when MS2830A-045 is installed) ± (Accuracy of reference frequency × Carrier frequency + 8.0 Hz) (In the CC of the center frequency when the center frequency is from 2700 MHz to 4000 MHz and MS2830A-078 is installed) (At the input level of -4 dBm when MS2830A-045 is installed)	
	Residual Vector Error	After CAL execution at 18° to 28°C At measurement Interval = 10 subframe <1.0% (rms) (Excluding the Batch Measurement when MS269xA-078 is not installed or MS269xA-004 is installed) <1.3% (rms) (In the CC of the center frequency when MS269xA-078 is installed)		
	Tx Power Measurement Accuracy (This is found from root sum of squares (RSS) of absolute amplitude accuracy and in-band frequency characteristics of main frame.)	After CAL execution, input attenuator ≥10 dB, at 18° to 28°C, the input signal is within the measurement level range and below the value set in Input Level. Excluding the Batch Measurement when the MS269xA-004 is installed. ±0.6 dB (at Preamp Off, or Preamp not installed.) ±1.1 dB (at Preamp On)		±0.6 dB (at Preamp Off, or Preamp not installed.)
Waveform Display	Provides functions for displaying waveforms below. Constellation, EVM vs. Subcarrier, EVM vs. Symbol, Power vs. Resource Block, EVM vs. Resource Block, Spectral Flatness			
Adjacent Channel Leakage Power Measurement	Measurement Method	Executes the adjacent channel power measurement function of the Spectrum Analyzer or Signal Analyzer.		
Occupied Bandwidth Measurement	Measurement Method	Executes the occupied bandwidth measurement function of the Spectrum Analyzer or Signal Analyzer.		
Channel Power Measurement	Measurement Method	Executes the channel power measurement function of the Spectrum Analyzer or Signal Analyzer.		
Spectrum Emission Mask Measurement	Measurement Method	Executes the spectrum emission mask measurement function of the Spectrum Analyzer.		
Digitize Function	Function Overview	Capable of outputting captured waveform data to internal hard disk or external hard disk.		
	Waveform Data	Format: I, Q (32 bit floating point binary format) Level: Assumes as $\sqrt{I^2 + Q^2} = 1$ for 0 dBm input Level accuracy: Same as the absolute amplitude accuracy and in-band frequency characteristics of the signal analyzer.		
Replay Function	Function Overview	Analyzes traces of saved waveform data Format: I, Q (32 bit floating point binary format) Sampling rate: 50 MHz		

MX2690xxA series Measurement Software

LTE Downlink Measurement Software MX269020A
LTE-Advanced FDD Downlink Measurement Software MX269020A-001
LTE TDD Downlink Measurement Software MX269022A
LTE-Advanced TDD Downlink Measurement Software MX269022A-001 (Continued)

MS269xA

MS2830A

LTE TDD Downlink Measurement Software MX269022A, LTE-Advanced TDD Downlink Measurement Software MX269022A-001

Signal Analyzer		MS269xA	MS2830A	
Common Specifications	Channel Bandwidth	1.4, 3, 5, 10, 15, 20 MHz		
	Target Signals	LTE TDD Downlink		
	Capture Time	Auto: 5 frame Manual: 5 to 150 frame		
Modulation/ Frequency Measurement	Measurement Frequency Range	600 MHz to 4000 MHz	600 MHz to 4000 MHz (MS2830A-041/043/044/045) 600 MHz to 3600 MHz (MS2830A-040)	
	Measurement Level Range	-15 to +30 dBm (Preamp Off, or Preamp not installed) -15 to +10 dBm (Preamp On)		
	Carrier Frequency Measurement Accuracy	After CAL execution at 18° to 28°C For a signal of EVM = 1% When Downlink 10 Subframe is the measurement target		
		± (Accuracy of reference frequency × Carrier frequency + 3 Hz) (Excluding the Batch Measurement when MS269xA-004 is installed)	± (Accuracy of reference frequency × Carrier frequency + 3.5 Hz) (When the center frequency is from 600 MHz to 2700 MHz and MS2830A-078 is not installed) ± (Accuracy of reference frequency × Carrier frequency + 8.0 Hz) (When the center frequency is from 2700 MHz to 4000 MHz and MS2830A-078 is not installed) ± (Accuracy of reference frequency × Carrier frequency + 4.0 Hz) (In the CC of the center frequency when the center frequency is from 600 MHz to 2700 MHz and MS2830A-078 is installed) (At the input level of -4 dBm when MS2830A-045 is installed) ± (Accuracy of reference frequency × Carrier frequency + 8.0 Hz) (In the CC of the center frequency when the center frequency is from 2700 MHz to 4000 MHz and MS2830A-078 is installed) (At the input level of -4 dBm when MS2830A-045 is installed)	
	Residual Vector Error	After CAL execution at 18° to 28°C When Downlink 10 Subframe is the measurement target		
		<1.0% (rms) (Excluding the Batch Measurement when MS269xA-078 is not installed or MS269xA-004 is installed) <1.3% (rms) (In the CC of the center frequency when MS269xA-078 is installed)	<1.3% (rms) (When MS2830A-078 is not installed. At the input level of -4 dBm when MX2830A-045 is installed) <1.3% (rms) (When MS2830A-078 is installed, in the CC of the center frequency. At the input level of -4 dBm when MX2830A-045 is installed)	
Tx Power Measurement Accuracy (This is found from root sum of squares (RSS) of absolute amplitude accuracy and in-band frequency characteristics of main frame.)	After CAL execution, input attenuator ≥10 dB, at 18° to 28°C, the input signal is within the measurement level range and below the value set in Input Level. Excluding the Batch Measurement when the MS269xA-004 is installed. ±0.6 dB (at Preamp Off, or Preamp not installed.) ±1.1 dB (at Preamp On)		±0.6 dB (at Preamp Off, or Preamp not installed.)	
Waveform Display	Provides functions for displaying waveforms below. Constellation, EVM vs. Subcarrier, EVM vs. Symbol, Power vs. Resource Block, EVM vs. Resource Block, Spectral Flatness			
Adjacent Channel Leakage Power Measurement	Measurement Method	Executes the adjacent channel power measurement function of the Spectrum Analyzer or Signal Analyzer.		
Occupied Bandwidth Measurement	Measurement Method	Executes the occupied bandwidth measurement function of the Spectrum Analyzer or Signal Analyzer.		
Channel Power Measurement	Measurement Method	Executes the channel power measurement function of the Spectrum Analyzer or Signal Analyzer.		
Spectrum Emission Mask Measurement	Measurement Method	Executes the spectrum emission mask measurement function of the Spectrum Analyzer.		
Digitize Function	Function Overview	Capable of outputting captured waveform data to internal hard disk or external hard disk.		
	Waveform Data	Format: I,Q (32 bit floating point binary format) Level: Assumes as $\sqrt{I^2 + Q^2} = 1$ for 0 dBm input Level accuracy: Same as the absolute amplitude accuracy and in-band frequency characteristics of the signal analyzer.		
Replay Function	Function Overview	Analyzes traces of saved waveform data Format: I, Q (32 bit floating point binary format) Sampling rate: 50 MHz		
Power vs. Time	Function Overview	Provides measurements for Transmitter OFF Power, Time Mask, and Transmitter Transient Period. This function can be used only in the MS269xA series.		
	Dynamic Range	121.4 dB (nom.)*1, *2		

*1: This is the value when Channel bandwidth is 5 MHz. For the other channel bandwidth, the following formula can be used.
 $10 \log_{10}(\text{Channel bandwidth}/5.0 \text{ MHz}) \text{ dB}$

*2: Wide Dynamic Range = On, Noise Correction = On

MX2690xxA series Measurement Software

LTE Uplink Measurement Software MX269021A LTE-Advanced FDD Uplink Measurement Software MX269021A-001 LTE TDD Uplink Measurement Software MX269023A LTE-Advanced TDD Uplink Measurement Software MX269023A-001

MS269xA

MS2830A

LTE Uplink Measurement Software MS269021A is for testing RF characteristics of 3GPP LTE FDD Uplink signal. LTE-Advanced FDD Uplink Measurement Software MX269021A-001 expands the Carrier Aggregation measurement function to MX269021A.

LTE Uplink Measurement Software MS269023A is for testing RF characteristics of 3GPP LTE TDD Uplink signal. LTE-Advanced TDD Uplink Measurement Software MX269023A-001 expands the Carrier Aggregation measurement function to MX269023A.

These applications improve the quality and efficiency of 3GPP LTE terminal and device component development and manufacturing.

Features

■ Support Testing of 3GPP TS 36.521-1 V10.5.0 (2013-03) Uplink RF Characteristics

■ Versatile Analysis Results Formats and Graphs

- Full Output Power, Frequency Error, and EVM
- Power and EVM for each Physical channel
- Both sub-carrier and symbol EVM and I/Q constellation displays
- Spectrum flatness/graph: Amplitude, Phase and Group Delay frequency characteristics
- Time Based EVM
- EVM vs. Demod-Symbol
- In-Band Emission
- Power vs. Time

■ Replay Function for Troubleshooting Faults

■ Measurement Items

[Text Display]

- Frequency Error
- Output Power
- EVM (rms)/(peak)
- Origin Offset
- Timing Offset (External Trigger)

[Graphical Display]

- Constellation
- EVM vs. Subcarrier
- EVM vs. Symbol
- Spectral Flatness
- Time Based EVM
- EVM vs. Demod-Symbol
- In-Band Emission

[Summary Display]

- PUSCH EVM (rms)/(peak)
- DMRS EVM (rms)/(peak)
- Frequency Error
- Output Power, Mean Power
- EVM (rms)/(peak)
- Origin Offset
- Time Offset
- Total EVM (Time Based)
- PUSCH QPSK/16QAM/64QAM EVM (Time Based)
- Total EVM (Frequency Based)
- PUSCH ALL/QPSK/16QAM/64QAM EVM
- DMRS EVM
- Frequency Error vs. Slot
- Origin Offset vs. Slot
- In-Band Emission
- Inside/Outside Flatness
- EVM Equalizer Spectrum Flatness

Measurement Functions

• Constellation/Numerical Results

The Constellation/Numerical value results are displayed.

- Frequency Error
- Output Power (Mean power in 31.25 MHz bandwidth)
- Mean Power (Mean power in channel bandwidth)
- EVM [Peak/rms]
- Origin Offset
- Time Offset (time offset between the trigger input and head of the frame)

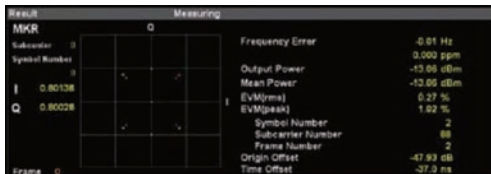

• EVM vs. Subcarrier

This displays the EVM vs. Subcarrier graph (horizontal axis = Subcarrier, vertical axis = EVM) at the bottom of the screen. The following EVM can be selected by switching EVM vs. Subcarrier View.

- Averaged over all Symbols: Mean value of all analysis symbols
- Each Symbol: Value of symbol selected by marker

It is useful for checking in-band interference signals.

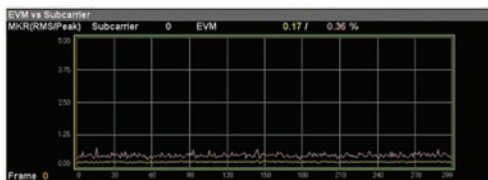

• EVM vs. Symbol

This displays the EVM vs. Symbol graph (horizontal axis = Symbol, vertical axis = EVM) at the bottom of the screen.

It is useful for checking characteristics in the time direction and faults at a specific symbol.



• Spectral Flatness

Four kinds of graphs are switched.

1. Amplitude vs. Subcarrier
Relative power of each subcarrier to average power of all subcarriers
2. Difference Amplitude vs. Subcarrier
Power difference between adjoined subcarriers
3. Phase vs. Subcarrier
Phase error of each subcarrier
4. Group Delay
Group delay between adjoined subcarriers

It is useful for checking frequency response (Amplitude and Group Delay).



• Time Base EVM

This displays a graph of each measured symbol in the time domain (horizontal axis) vs. EVM (vertical axis) at the bottom of the screen. The results are displayed for symbols that have a PUSCH.

It is useful for checking characteristics in the time direction and faults at a specific symbol.



• EVM vs. Demodulation Symbol

This displays a graph of the EVM vs. Demodulation Symbol (horizontal axis = Demodulation Symbol, vertical axis = EVM) at the bottom of the screen.

It is useful for checking characteristics in the time direction and faults at a specific symbol.

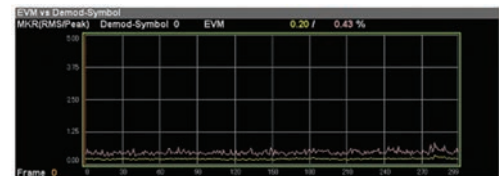

MX2690xxA series Measurement Software

LTE Uplink Measurement Software MX269021A
 LTE-Advanced FDD Uplink Measurement Software MX269021A-001
 LTE TDD Uplink Measurement Software MX269023A
 LTE-Advanced TDD Uplink Measurement Software MX269023A-001 (Continued)

MS269xA MS2830A

In-Band Emission

The following two types of graph can be selected and displayed at the bottom of the screen by switching In-Band Emission View.

Averaged over all Slots: Average of In-Band Emission for measured slots

Each Slot: In-Band Emission value for each slot specified by Graph Slot Number

It is useful for checking in-band emission at a specific subcarrier and resource block.



Summary Display Function

This function batch-displays the power and EVM for each channel.

Summary				Page No. 1 / 10	
Inte EVM	EVM Final	rms	0.21 %	EVM / Demod-Symbol / Symbol / Frame	
(time based)	EVM High	prk	0.75 %	219 / 43 / 0	
	EVM Low	rms	0.21 %	219 / 43 / 0	
	EVM Low	prk	0.75 %	219 / 43 / 0	
PUSCH QPSK EVM	EVM Final	rms	0.21 %	219 / 43 / 0	
(time based)	EVM High	prk	0.75 %	219 / 43 / 0	
	EVM Low	rms	0.21 %	219 / 43 / 0	
	EVM Low	prk	0.75 %	219 / 43 / 0	

Page 1: List of EVM and Power for Each Channel Uplink (PUSCH) (MX269023A)

Replay Function for Troubleshooting Faults

Up to 150 frames of LTE TDD signals can be captured as a file for replay by the LTE TDD Measurement Software to perform EVM measurement analyses, etc.*

*: Batch measurement is not supported when the MX269022A-001 is installed.

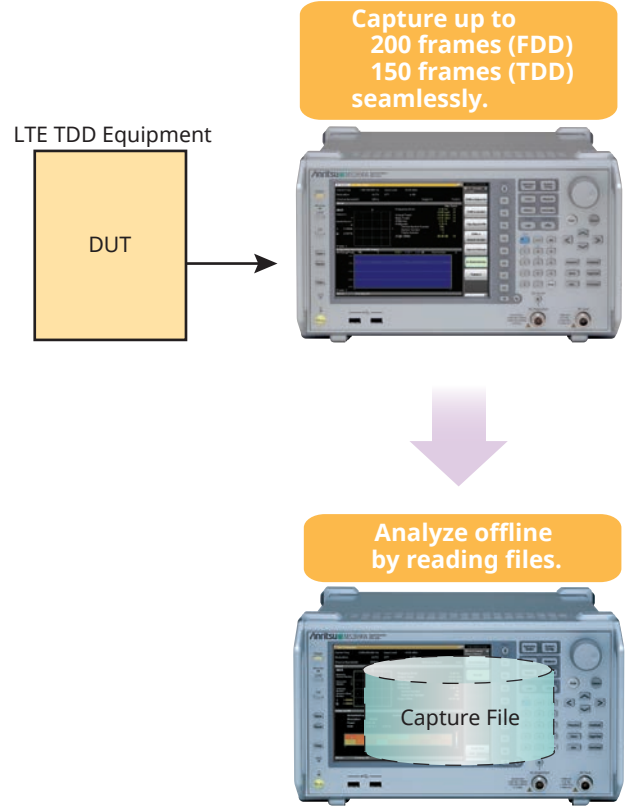

Example of R&D use

- Save data for comparing each DUT test version
- Supports comparison of retrofitting improvement effects

Example of production line use

- Save delivery inspection data
- Supports rechecking of performance data for troubleshooting post-delivery faults

MX2690xxA series Measurement Software

LTE Uplink Measurement Software MX269021A
LTE-Advanced FDD Uplink Measurement Software MX269021A-001
LTE TDD Uplink Measurement Software MX269023A
LTE-Advanced TDD Uplink Measurement Software MX269023A-001 (Continued)

MS269xA

MS2830A

Specifications

The specification is the value after 30-minute warm-up at a constant ambient temperature.
 The specifications are defined under the following condition unless otherwise specified.
 Attenuator mode: Mechanical Attenuator Only (MS2830A only)

LTE Uplink Measurement Software MX269021A , LTE-Advanced FDD Uplink Measurement Software MX269021A-001

Signal Analyzer	MS269xA	MS2830A	
Common Specifications	Channel Bandwidth	1.4, 3, 5, 10, 15, 20 MHz	
	Target Signals	Uplink	
	Span Setting	The LTE-Advanced is selectable when MX269021A-001 is installed. When LTE is selected: Span = 31.25 MHz fixed When LTE-Advanced is selected, and when Option 077/177/078/178 is not installed: Span = 31.25 MHz When LTE-Advanced is selected, and when Option 077/177 is installed: Span = 62.5 MHz When LTE-Advanced is selected, and when Option 078/178 is installed: Span = 125 MHz	
	Capture Time	The condition "When Span = 62.5 MHz and 125 MHz" is applied when MX269021A-001 is installed. <ul style="list-style-type: none"> When Span = 31.25 MHz Capture Time = Auto: 1 Frame Capture Time = Manual: 1 to 200 Frame When Span = 62.5 MHz Capture Time = Auto: 1 Frame Capture Time = Manual: 1 to 100 Frame When Span = 125 MHz Capture Time = Auto: 1 Frame Capture Time = Manual: 1 to 50 Frame 	
Modulation/ Frequency Measurement	Measurement Frequency Range	400 MHz to 5000 MHz	MS2830A-040: 400 MHz to 3600 MHz MS2830A-041/043/044/045: 400 MHz to 5000 MHz
	Measurement Level Range	-15 to +30 dBm (Preamp Off, or Preamp not installed.) -15 to +10 dBm (Preamp On)	-15 to +30 dBm (Preamp Off, or Preamp not installed.)
	Carrier Frequency Accuracy	After CAL execution at 18° to 28°C. For a signal of EVM = 1%. For Measurement Interval = 10 Subframe ± (Accuracy of reference frequency × Carrier frequency + 8 Hz)	± (Accuracy of reference frequency × Carrier frequency + 8 Hz) (At the input level is -4 dBm when MS2830A-045 is installed)
	Residual EVM	After CAL execution at 18° to 28°C. For Measurement Interval = 10 Subframe. The condition "When Span = 62.5 MHz or 125 MHz" is applied when MX269021A-001 is installed. <1.0% (rms) (When Span = 31.25 MHz) <1.3% (rms) (When Span = 62.5 MHz or 125 MHz)	<1.2% (rms) (When Span = 31.25 MHz) <1.3% (rms) (When Span = 62.5 MHz or 125 MHz) (At the input level is -4 dBm when MS2830A-045 is installed)
	Transmitter Power Accuracy	Transmitter power accuracy is calculated from an RSS (root summed square) error of the absolute amplitude accuracy and the in-band frequency characteristics of the MS2690A/MS2691A/MS2692A or MS2830A. After CAL execution, input attenuator ≥10 dB, at 18° to 28°C, the input signal measured is within the measurement level range and below the value set in Input Level, when Span = 31.25 MHz. ±0.6 dB (Preamp Off, or Preamp not installed.) ±1.1 dB (Preamp On)	±0.6 dB (Preamp Off, or Preamp not installed.)
	Measurement Target Channel Signal	LTE Selected: <ul style="list-style-type: none"> • PUSCH • PUCCH • SRS • PRACH LTE-Advanced Selected: <ul style="list-style-type: none"> • PUSCH • PUCCH Measures and displays the result per channel. The channel setting is mutually exclusive.	
	Waveform Display	Provides functions for displaying waveforms below. <ul style="list-style-type: none"> Constellation EVM vs. Subcarrier EVM vs. Symbol Time Based EVM EVM vs. Demod-Symbol Spectral Flatness In-Band Emission Power vs. Time 	
Adjacent Channel Leakage Power Measurement	Measurement Method	Executes the adjacent channel power measurement function of the Spectrum Analyzer or Signal Analyzer.	
Occupied Bandwidth Measurement	Measurement Method	Executes the occupied bandwidth measurement function of the Spectrum Analyzer or Signal Analyzer.	

MX2690xxA series Measurement Software

LTE Uplink Measurement Software MX269021A LTE-Advanced FDD Uplink Measurement Software MX269021A-001 LTE TDD Uplink Measurement Software MX269023A LTE-Advanced TDD Uplink Measurement Software MX269023A-001 (Continued)

MS269xA

MS2830A

Signal Analyzer		MS269xA	MS2830A
Channel Power Measurement	Measurement Method	Executes the channel power measurement function of the Spectrum Analyzer or Signal Analyzer.	
Spectrum Emission Mask Measurement	Measurement Method	Executes the spectrum emission mask measurement function of the Spectrum Analyzer.	
Digitize Function	Function Overview	Capable of outputting captured waveform data to internal hard disk or external hard disk.	
	Waveform Data	Format: I, Q (32 bit floating point binary format) Level: Assumes as $\sqrt{I^2 + Q^2} = 1$ for 0 dBm input Level accuracy: Same as the absolute amplitude accuracy and in-band frequency characteristics of the signal analyzer.	
Replay Function		Analyzes traces of saved waveform data Format: I, Q (32 bit floating point binary format) Sampling rate: The condition "When Span = 62.5 MHz and 125 MHz" is applied when MX269021A-001 is installed. 50 MHz (when Span = 31.25 MHz) 100 MHz (when Span = 62.5 MHz) 200 MHz (when Span = 125 MHz)	
Component Carrier (CC) Allocated Condition	Maximum Number of CCs	2	
	Channel Bandwidth of Each CC	1.4, 3, 5, 10, 15, 20 MHz	
	Frequency Offset Range of Each CC	- (Span - Channel bandwidth of each CC)/2 to (Span - Channel bandwidth of each CC)/2	

LTE TDD Uplink Measurement Software MX269023A, LTE-Advanced TDD Uplink Measurement Software MX269023A-001

Signal Analyzer		MS269xA	MS2830A
Common Specifications	Channel Bandwidth	1.4, 3, 5, 10, 15, 20 MHz	
	Target Signals	Uplink	
	Span Setting	The LTE-Advanced is selectable when MX269023A-001 is installed. When LTE is selected: Span = 31.25 MHz fixed When LTE-Advanced is selected, and when Option 077/177/078/178 is not installed: Span = 31.25 MHz When LTE-Advanced is selected, and when Option 077/177 is installed: Span = 62.5 MHz When LTE-Advanced is selected, and when Option 078/178 is installed: Span = 125 MHz	
Modulation/Frequency Measurement	Capture Time	The condition "When Span = 62.5 MHz and 125 MHz" is applied when MX269023A-001 is installed. <ul style="list-style-type: none"> When Span = 31.25 MHz Capture Time = Auto: 5 Frame Capture Time = Manual: 5 to 150 Frame When Span = 62.5 MHz Capture Time = Auto: 5 Frame Capture Time = Manual: 5 to 100 Frame When Span = 125 MHz Capture Time = Auto: 5 Frame Capture Time = Manual: 5 to 50 Frame 	
	Measurement Frequency Range	400 MHz to 5000 MHz	MS2830A-040: 400 MHz to 3600 MHz MS2830A-041/043/044/045: 400 MHz to 5000 MHz
	Measurement Level Range	-15 to +30 dBm (Preamp Off, or Preamp not installed.) -15 to +10 dBm (Preamp On)	-15 to +30 dBm (Preamp Off, or Preamp not installed.)
Carrier Frequency Accuracy	Carrier Frequency Accuracy	\pm (Accuracy of reference frequency \times Carrier frequency + 8 Hz)	\pm (Accuracy of reference frequency \times Carrier frequency + 8 Hz) (At the input level is -4 dBm when MS2830A-045 is installed)
	Residual EVM	After CAL execution at 18° to 28°C. For Measurement Interval = 10 Subframe. The condition "When Span = 62.5 MHz or 125 MHz" is applied when MX269023A-001 is installed.	$<1.2\%$ (rms) (When Span = 31.25 MHz) $<1.3\%$ (rms) (When Span = 62.5 MHz or 125 MHz) (At the input level is -4 dBm when MS2830A-045 is installed)
	Transmitter Power Accuracy	Transmitter power accuracy is calculated from an RSS (root summed square) error of the absolute amplitude accuracy and the in-band frequency characteristics of the MS2690A/MS2691A/MS2692A or MS2830A. After CAL execution, input attenuator ≥ 10 dB, at 18° to 28°C, the input signal measured is within the measurement level range and below the value set in Input Level, when Span = 31.25 MHz.	± 0.6 dB (Preamp Off, or Preamp not installed.) ± 1.1 dB (Preamp On)
		± 0.6 dB (Preamp Off, or Preamp not installed.)	± 0.6 dB (Preamp Off, or Preamp not installed.)

MX2690xxA series Measurement Software

LTE Uplink Measurement Software MX269021A
 LTE-Advanced FDD Uplink Measurement Software MX269021A-001
 LTE TDD Uplink Measurement Software MX269023A
 LTE-Advanced TDD Uplink Measurement Software MX269023A-001 (Continued)

MS269xA

MS2830A

Signal Analyzer		MS269xA	MS2830A
Modulation/ Frequency Measurement	Measurement Target Channel Signal	LTE Selected: <ul style="list-style-type: none"> • PUSCH • PUCCH • PRACH LTE-Advanced Selected: <ul style="list-style-type: none"> • PUSCH • PUCCH Measures and displays the result per channel. The channel setting is mutually exclusive.	
	Waveform Display	Provides functions for displaying waveforms below. <ul style="list-style-type: none"> Constellation EVM vs. Subcarrier EVM vs. Symbol Time Based EVM EVM vs. Demod-Symbol Spectral Flatness In-Band Emission Power vs. Time 	
Adjacent Channel Leakage Power Measurement	Measurement Method	Executes the adjacent channel power measurement function of the Spectrum Analyzer or Signal Analyzer.	
Occupied Bandwidth Measurement	Measurement Method	Executes the occupied bandwidth measurement function of the Spectrum Analyzer or Signal Analyzer.	
Channel Power Measurement	Measurement Method	Executes the channel power measurement function of the Spectrum Analyzer or Signal Analyzer.	
Spectrum Emission Mask Measurement	Measurement Method	Executes the spectrum emission mask measurement function of the Spectrum Analyzer.	
Digitize Function	Function Overview	Capable of outputting captured waveform data to internal hard disk or external hard disk.	
	Waveform Data	Format: I, Q (32 bit floating point binary format) Level: Assumes as $\sqrt{I^2 + Q^2} = 1$ for 0 dBm input Level accuracy: Same as the absolute amplitude accuracy and in-band frequency characteristics of the signal analyzer.	
Replay Function		Analyzes traces of saved waveform data Format: I, Q (32 bit floating point binary format) Sampling rate: The condition "When Span = 62.5 MHz and 125 MHz" is applied when MX269021A-001 is installed. 50 MHz (when Span = 31.25 MHz) 100 MHz (when Span = 62.5 MHz) 200 MHz (when Span = 125 MHz)	
Component Carrier (CC) Allocated Condition	Maximum Number of CCs	2	
	Channel Bandwidth of Each CC	1.4, 3, 5, 10, 15, 20 MHz	
	Frequency Offset Range of Each CC	- (Span - Channel bandwidth of each CC)/2 to (Span - Channel bandwidth of each CC)/2	

MX2690xxA series Measurement Software

CDMA2000 Forward Link Measurement Software MX269024A All Measure Function MX269024A-001 EV-DO Forward Link Measurement Software MX269026A All Measure Function MX269026A-001

MS269xA

MS2830A

The CDMA2000 Forward Link Measurement Software MX269024A supports measurement of RF characteristics of 3GPP2 C.S0002/C.S0010 CDMA2000 Forward Link signals. The EV-DO Forward Link Measurement Software MX269026A supports measurement of RF characteristics of 3GPP2 C.S0024/C.S0032 EV-DO Forward Link signals.

Installing the All Measure Function MX269024A-001 in a unit in which the MX269024A has been installed supports single-capture batch-measurement of multiple CDMA2000 Tx characteristics, such as modulation analysis accuracy, power spectrum, etc.

Similarly, installing the All Measure Function MX269026A-001 in a unit in which the MX269026A has been installed supports single-capture batch-measurement of multiple EV-DO Tx characteristics such as modulation accuracy, power spectrum, etc.

Features

■ Support Testing of 3GPP2 CDMA2000/EV-DO Revision 0, Revision A Forward Link RF Characteristics

■ Easy Setting of Measurement Conditions

- Signal analyzer automatically synchronized to input signal
- CDMA2000 Rev. 0 (Subtype0/1) and Rev. A (Subtype2) switching: CDMA2000
- Data Tx and Idle state switching: EV-DO

■ Versatile Analysis Results Formats and Graphs

- Text displays for Frequency Error, Output Power, Waveform Quality, p, Timing Error, etc.
- Code Domain Power Graph
- Conducted Spurious Emissions
- Occupied Bandwidth
- Power vs. Time (only EV-DO)

■ All Measurement Function

Batch-measures and list displays multiple items, such as modulation accuracy and power spectrum (requires installation of All Measure Function option)

MX269024A CDMA2000 Forward Link

• Code Domain Graph

The code domain analysis result (graph and numerical value) is displayed at the top of the screen. This is the result for the slot set as Target Slot Number.

The numeric modulation analysis result is displayed at the bottom of the screen as an average for the number of slots set as Measurement Interval.

In addition, the measurement result is averaged when Average is On.



Code Domain Screen: CDMA2000 Forward Link

• All Measure Screen

Installing the MX269024A-001 All Measure Function supports high-speed batch-measurement of CDMA2000 Forward Link multiple Tx characteristics, such as modulation accuracy, power spectrum, etc.



All Measure Screen: CDMA2000 Forward Link

MX2690xxA series Measurement Software

CDMA2000 Forward Link Measurement Software MX269024A
All Measure Function MX269024A-001
EV-DO Forward Link Measurement Software MX269026A
All Measure Function MX269026A-001 (Continued)

MS269xA **MS2830A**

MX269026A EV-DO Forward Link

Code Domain Graph

The code domain analysis result (graph and numerical value) is displayed at the top of the screen. "MAC" or "Data" is switched at the code domain screen.

The numeric modulation analysis result is displayed at the bottom of the screen.



Code Domain Power Screen: EV-DO Forward Link

All Measure Screen

Installing the MX269026A-001 All Measure Function supports high-speed batch-measurement of EV-DO Forward Link multiple Tx characteristics, such as modulation accuracy, power spectrum, etc.



All Measure Screen: EV-DO Forward Link

Power vs. Time Graph

The Time Domain Graph (Avg./Max./Min. level) is displayed at the top of the screen. The three screens are switched as follows:

Halfslot

Displays half slot time.

- 1st Half slot: Displays first half
- 2nd Half slot: Displays second half
- Full slot: Displays mean of first and second half

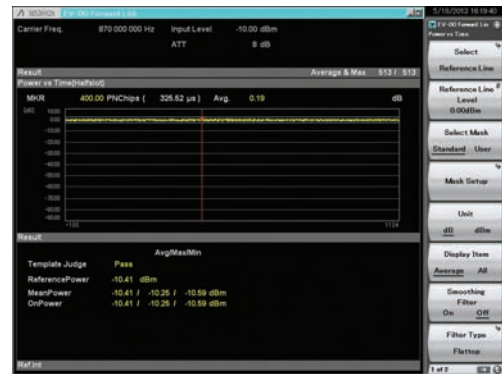

Power vs. Time Screen (Data Tx state): EV-DO Forward Link



Power vs. Time Screen (Idle state): EV-DO Forward Link

OnPortion

Displays Pilot/MAC.



Power vs. Time Screen - OnPortion- (Idle state): EV-DO Forward Link

MX2690xxA series Measurement Software

CDMA2000 Forward Link Measurement Software MX269024A
All Measure Function MX269024A-001
EV-DO Forward Link Measurement Software MX269026A
All Measure Function MX269026A-001 (Continued)

MS269xA

MS2830A

■ Ramp

Displays Ramp Part of Pilot/MAC.



Power vs. Time Screen - Ramp - (Idle state):
EV-DO Forward Link

Specifications

The specification is the value after 30-minute warm-up at a constant ambient temperature.

The specifications are defined under the following condition unless otherwise specified.

Attenuator mode: Mechanical Attenuator Only (MS2830A only)

Signal Analyzer		MS269xA	MS2830A
Modulation/ Frequency Measurement	Frequency Range	400 MHz to 2700 MHz	
	Measurement Level Range	-15 to +30 dBm (Preamp Off, or Preamp not installed) -15 to +10 dBm (Preamp On)	-15 to +30 dBm (Preamp Off, or Preamp not installed)
	Carrier Frequency Measurement Accuracy	At 18° to 28°C, after calibration, EVM = 1% signal ± (Accuracy of reference frequency × Carrier frequency + 10 Hz)	
	Residual Vector Error	At 18° to 28°C, after calibration <1.0% (rms)	<1.5% (rms)
	Waveform Quality (p)	>0.99990	>0.99978
Amplitude Measurement	Tx Power Measurement Accuracy (This is found from root sum of squares (RSS) of absolute amplitude accuracy and in-band frequency characteristics of main frame.)	At 18° to 28°C, after calibration, with input attenuator ≥10 dB and input signal in measurement level range and less than Input level ±0.6 dB (Preamp Off, or Preamp not installed) ±1.1 dB (Preamp On)	±0.6 dB (Preamp Off, or Preamp not installed)
Code Domain Measurement	Power Accuracy	At 18° to 28°C, after calibration, input signal in measurement level range and less than Input level, MAC region is average ≥16 ±0.02 dB (Code Power ≥-10 dBc) ±0.05 dB (Code Power ≥-20 dBc) ±0.10 dB (Code Power ≥-30 dBc)	
Measurement Items	MX269024A	Modulation Analysis	
		<ul style="list-style-type: none"> • Frequency Error • RF Level • ρ • Vector Error (Peak/rms) • Origin Offset • TIM (Difference between "Set position of PN Offset of RF input" and "Trigger input") 	
		Code Domain Graph	
	MX269026A	Code Domain Graph	
		<ul style="list-style-type: none"> • Frequency Error • ρ (pilot/MAC/Data/Overall) • Vector Error (Peak/rms) • Origin Offset • Data Modulation Scheme • Timing Error • (Difference between "Set position of PN Offset of RF input" and "Trigger input") • MAC Inactive CH • Data Active CH 	
Code Domain Graph			
		I Code/CH/Power/ρ, Q code/CH/Power/ρ, Total Pilot Power, Total MAC Power, Total Data Power, I Active CH, I Inactive CH, Q Active CH, Q Inactive CH	
		Power vs. Time Graph	
		Average, Maximum, Minimum	
		Adjacent Channel Leakage Power, Occupied Bandwidth, Channel Power, Spectrum Emission Mask	

MX2690xxA series Measurement Software

WLAN (802.11) Measurement Software MX269028A 802.11ac (80 MHz) Measurement Software MX269028A-001 802.11ac (160 MHz) Measurement Software MX269028A-002

MS269xA

MS2830A

Installing the WLAN (802.11) Measurement Software MX269028A in the MS269xA/MS2830A main frame supports modulation analysis of IEEE 802.11n/p/a/b/g/j signals with display of numerical and graphical results. The 802.11ac (80 MHz) Measurement Software MX269028A-001*1, and 802.11ac (160 MHz) Measurement Software MX269028A-002*2 are MX269028A software options for modulation analysis of IEEE 802.11ac signals. Moreover, Tx tests of RF signals are supported when used in combination with MS269xA/MS2830A functions, such as adjacent channel leakage power, occupied bandwidth, spectrum emission mask, spurious, etc.

*1: Only For MS2830A. Requires MX269028A.

*2: Only For MS269xA. Requires MX269028A.

Features

- One software package supporting IEEE 802.11n/p/a/b/g/j signal (MX269028A)
- Adding optional software supports modulation analysis of IEEE 802.11ac signal (MX269028A-001/002).
MX269028A-001: Supports up to 80-MHz bandwidth. (Only for MS2830A)
MX269028A-002: Supports up to 160-MHz bandwidth. (Only for MS269xA)
- Displays numerical results and analysis graphs (for R&D, quality assurance and manufacturing)
- Catch and replay function*1 (saves*2 signals for later modulation analysis troubleshooting)

*1: This function is not supported when the MX269028A-002 (only for MS269xA) is installed and the channel bandwidth is set to 160 MHz.

*2: Data for 1 burst signal

Evaluation of Tx Characteristics for WLAN Modulation Accuracy (EVM)

The MX269028A supports WLAN modulation analysis and has an easy-to-use graph function for verification at Tx tests of WLAN equipment and parts.

■ Measurement Signals

MX269028A

- IEEE 802.11n (HT-Mixed, HT-Greenfield, Non-HT)
- IEEE 802.11p
- IEEE 802.11a
- IEEE 802.11b
- IEEE 802.11g ERP-DSSS/CCK
- IEEE 802.11g ERP-OFDM
- IEEE 803.11g DSSS-OFDM
- IEEE 802.11j

Measures both continuous and burst signals.

MX269028A-001/002

- IEEE 802.11ac (VHT)

Measures burst signals only.

■ Capture & Replay Function*1

When faults are detected, this function captures*2 on-site signals to internal/external hard disk for later troubleshooting using analysis functions.

*1: This function is not supported when the MX269028A-002 (only for MS269xA) is installed and the channel bandwidth is set to 160 MHz.

*2: Data for 1 burst signal

■ MS269xA/MS2830A Main Frame Functions

The following measurements are performed by calling the main-frame spectrum analyzer functions. These functions prepare each measurement standard templates.

- Adjacent Channel Leakage Power
- Occupied Bandwidth
- Spectrum Emission Mask
- Spurious Emission

■ Supports IEEE 802.11ac signals up to 160-MHz bandwidth

The IEEE 802.11ac measurement range varies as follows, depending on the Analysis Bandwidth Extension option configuration.

Table 1. Supported measurement range for IEEE 802.11ac signals

Model			Bandwidth of IEEE 802.11ac Signal				
Main frame	Measurement software	Analysis Bandwidth Extension Option Configuration	20 MHz	40 MHz	80 MHz	160 MHz	80 MHz + 80 MHz
MS269xA	MX269028A-002	MS269xA-078*1 installed	✓	✓	✓	✓	✓*6
		MS269xA-077/004*2 installed	✓	✓			
		Standard	✓	✓			
MS2830A	MX269028A-001	MS2830A-078*3 installed	✓	✓	✓*7		
		MS2830A-077*4 installed	✓	✓			
		MS2830A-005/009*5 installed	✓	✓			

*1: MS269xA-078 Analysis Bandwidth Extension to 125 MHz

*2: MS269xA-077 Analysis Bandwidth Extension to 62.5 MHz

MS269xA-004 Analysis Bandwidth Extension to 125 MHz

*3: MS2830A-078 Analysis Bandwidth Extension to 125 MHz

*4: MS2830A-077 Analysis Bandwidth Extension to 62.5 MHz

*5: MS2830A-005 Analysis Bandwidth Extension to 31.25 MHz

MS2830A-009 Analysis Bandwidth Extension to 31.25 MHz for Millimeter-wave

*6: Measurement is required for each carrier signal (80-MHz bandwidth)

*7: Measurement is only possible when the carrier signal (80-MHz bandwidth) is input due to the effect of the image response.

MX2690xxA series Measurement Software

WLAN (802.11) Measurement Software MX269028A
802.11ac (80 MHz) Measurement Software MX269028A-001
802.11ac (160 MHz) Measurement Software MX269028A-002 (Continued)

MS269xA

MS2830A

■ Analysis Function (Numerical Results and Graph display)

Item		11n/p/a/j 11g (ERP-OFDM) 11g (DSSS-OFDM)	11b 11g (ERP-DSSS/CCK)	11ac
Modulation Analysis Function	Numerical Result Display			
	Frequency Error	✓	✓	✓
	Symbol Clock Error/Chip Clock Error	✓	✓	✓
	Transmit Power	✓	✓	✓
	Time Offset	✓	✓	✓
	EVM [rms]	✓	✓	✓
	Data EVM, Pilot EVM	✓	—	✓
	SIG EVM (rms)	✓*1	—	—
	L-SIG EVM (rms)	✓*2	—	✓
	HT-SIG EVM (rms)	✓*3	—	—
	VHT-SIG-A EVM (rms), VHT-SIG-B EVM (rms)	—	—	✓
	EVM [Peak]	✓	✓	✓
	Symbol Number, Subcarrier Number/Chip Number	✓	✓	✓
	Quadrature Error	✓	—	✓*6
	IQ Gain Imbalance	✓	—	✓*6
	Center Frequency Leakage	✓	—	✓
	Spectral Flatness (Amplitude/Phase/Group Delay)	✓	—	✓
	Outside Subcarrier Amplitude Max and Min Value	✓	—	✓
	Inside Subcarrier Amplitude Max and Min Value	✓	—	✓
	Phase Error	—	✓	—
	Magnitude Error	—	✓	—
	IQ Origin Offset	—	✓	—
	Detect Parameter	✓	✓	✓
	Data Rate, Modulation Method, Symbol Length/Chip Length	✓*4	✓	—
	Preamble	✓*5	✓	—
	MCS, Stream ID, Symbol Length, Guard Interval	✓*2	—	✓
	Graph Display			
	Constellation	✓	✓	✓
	EVM vs. Subcarrier	✓	—	✓
	EVM vs. Symbol/EVM vs. Chip	✓	✓	✓
Spectral Flatness (Amplitude/Phase/Group Delay)	✓	—	✓	
Phase Error vs. Chip	—	✓	—	
Eye diagram	—	✓	—	
Power vs. Time Function	Numerical Result Display			
	Transmit Power	✓	✓	—
	Power Flatness Max	✓	✓	—
	Carrier Off Power	✓	✓	—
	On/Off Ratio	✓	✓	—
	Peak Power Spectrum Density (PSD)	✓	✓	—
	Transient time (power-on ramp, power-off ramp)	—	✓	—
	Graph Display			
	Burst	✓	✓	—
	Transient	✓	✓	—

*1: IEEE 802.11a

*2: IEEE 802.11n

*3: IEEE 802.11n (HT-Mixed, HT-Greenfield)

*4: Exclude IEEE 802.11n

*5: IEEE 802.11g DSSS-OFDM

*6: Exclude Channel Bandwidth 160 MHz setting

MX2690xxA series Measurement Software

WLAN (802.11) Measurement Software MX269028A 802.11ac (80 MHz) Measurement Software MX269028A-001 802.11ac (160 MHz) Measurement Software MX269028A-002 (Continued)

MS269xA

MS2830A

Common Setup Parameter

Standard	MX269028A: IEEE 802.11n, IEEE 802.11p, IEEE 802.11a, IEEE 802.11b, IEEE 802.11g ERP-DSSS/CCK, IEEE 802.11g ERP-OFDM, IEEE 802.11g DSSS-OFDM, IEEE 802.11j MX269028A-001 or MX269028A-002: IEEE 802.11ac
Measuring Object	Burst Signal, Continuous Signals: IEEE 802.11n/p/a/b/g/j Burst Signal: IEEE 802.11ac
Channel Bandwidth	MX269028A IEEE 802.11n: 20 MHz, 40 MHz, 40 MHz (Upper), 40 MHz (Lower) IEEE 802.11j/p: 5, 10, 20 MHz MX269028A-001 IEEE 802.11ac: 20, 40, 80 MHz* MX269028A-002 IEEE 802.11ac: 20, 40, 80, 160 MHz*
PPDU Format	MX269028A IEEE 802.11n: Non-HT, HT-Mixed, HT-Greenfield MX269028A-001 IEEE 802.11ac: VHT

*: Refer to [Table1: Supported measurement range for IEEE 802.11ac signals]

Specifications

The specification is the value after 30-minute warm-up at a constant ambient temperature. Typical values are for reference only and are not guaranteed. Values are guaranteed after executing CAL at 18° to 28°C, and the measured signal is within the measurement level range and is less than or equal to Input Level.

The specifications are defined under the following condition unless otherwise specified.

Attenuator mode: Mechanical Attenuator Only (MS2830A only)

WLAN (802.11) Measurement software MX269028A

Signal Analyzer		MS269xA	MS2830A	
Standard		IEEE 802.11n HT Mixed, HT Greenfield, Non-HT, (Direct Mapping supported), MCS = 0 to 76 supported		
Modulation/ Frequency Measurements	Frequency Range	2.4 GHz band: 2412 MHz to 2472 MHz (channel No. 1 to 13) 2484 MHz (channel No. 14) 5 GHz band: 5180 MHz to 5320 MHz (channel No. 36 to 64) 5500 MHz to 5700 MHz (channel No. 100 to 140) 5745 MHz to 5825 MHz (channel No. 149 to 165)		
	Measurement Level Range	2.4 GHz band: -15 to +30 dBm (MS269xA Preamp Off, or Preamp not installed) -15 to +30 dBm (MS2830A Preamp Off, or Preamp not installed, MS2830A-045 not installed) -9 to +30 dBm (MS2830A Preamp Off, or Preamp not installed, MS2830A-045 installed) -30 to +10 dBm (Preamp On) 5 GHz band: -15 to +30 dBm (MS269xA Preamp Off, or Preamp not installed) -12 to +30 dBm (MS2830A Preamp Off, or Preamp not installed, MS2830A-045 not installed) -6 to +30 dBm (MS2830A Preamp Off, or Preamp not installed, MS2830A-045 installed) -30 to +10 dBm (Preamp On)		
	Carrier Frequency Accuracy	20 MHz channel	Burst length $\geq 250 \mu\text{s}$ \pm (Accuracy of reference frequency \times Carrier frequency + 13) Hz (2.4 GHz band) \pm (Accuracy of reference frequency \times Carrier frequency + 16) Hz (5 GHz band)	
		40 MHz channel	Burst length $> 250 \mu\text{s}$ \pm (Accuracy of reference frequency \times Carrier frequency + 62) Hz (2.4 GHz band) \pm (Accuracy of reference frequency \times Carrier frequency + 102) Hz (5 GHz band)	
	Residual Vector Error	20 MHz channel	Channel Estimation: SEQ, Phase Tracking: On, Amplitude Tracking: Off, Burst signal $\leq 1.2\%$ (rms) (2.4 GHz band) $\leq 1.6\%$ (rms) (5 GHz band)	$\leq 1.2\%$ (rms) (2.4 GHz band) (Preamp Off) $\leq 1.6\%$ (rms) (5 GHz band) (Preamp Off)
40 MHz channel		Channel Estimation: SEQ, Phase Tracking: On, Amplitude Tracking: Off, Burst signal $\leq 1.5\%$ (rms) (2.4 GHz band) $\leq 1.9\%$ (rms) (5 GHz band)	$\leq 1.6\%$ (rms) (2.4 GHz band) (Preamp Off) $\leq 2.0\%$ (rms) (5 GHz band) (Preamp Off)	
Center Frequency Leakage Floor		$\leq -50 \text{ dBc}$ (nom.)		
Amplitude Measurement	Tx Power Accuracy (This is found from root sum of squares (RSS) of absolute amplitude accuracy and in-band frequency characteristics of main frame.)	20 MHz channel	Input attenuator $\geq 10 \text{ dB}$ 2.4 GHz band: $\pm 0.6 \text{ dB}$ (Preamp Off, or Preamp not installed) $\pm 1.1 \text{ dB}$ (Preamp On) 5 GHz band: $\pm 0.6 \text{ dB}$ (Preamp Off, or Preamp not installed) $\pm 1.1 \text{ dB}$ (Preamp On)	
		40 MHz channel	Input attenuator $\geq 10 \text{ dB}$ 2.4 GHz band: $\pm 0.7 \text{ dB}$ (Preamp Off, or Preamp not installed) $\pm 1.1 \text{ dB}$ (Preamp On) 5 GHz band: $\pm 0.7 \text{ dB}$ (Preamp Off, or Preamp not installed) $\pm 1.1 \text{ dB}$ (Preamp On)	

MX2690xxA series Measurement Software

WLAN (802.11) Measurement Software MX269028A 802.11ac (80 MHz) Measurement Software MX269028A-001 802.11ac (160 MHz) Measurement Software MX269028A-002 (Continued)

MS269xA

MS2830A

Signal Analyzer		MS269xA	MS2830A
Standard		IEEE 802.11p	
Modulation/ Frequency Measurements	Frequency Range	5835 MHz to 5925 MHz (channel No. 167 to 185) 300 MHz to 862 MHz	
	Measurement Level Range	5835 MHz to 5925 MHz (Channel No. 167 to 185): -15 to +30 dBm (MS269xA Preamp Off, or Preamp not installed) -12 to +30 dBm (MS2830A Preamp Off, or Preamp not installed, MS2830A-045 not installed) -6 to +30 dBm (MS2830A Preamp Off, or Preamp not installed, MS2830A-045 installed) -30 to +10 dBm (Preamp On) 300 MHz to 862 MHz: -15 to +30 dBm (MS269xA Preamp Off, or Preamp not installed) -15 to +30 dBm (MS2830A Preamp Off, or Preamp not installed, MS2830A-045 not installed) -9 to +30 dBm (MS2830A Preamp Off, or Preamp not installed, MS2830A-045 installed) -30 to +10 dBm (Preamp On)	
Modulation/ Frequency Measurements	Carrier Frequency Accuracy	5 MHz channel: Burst length ≥ 1 ms, 10 MHz channel: Burst length ≥ 500 μ s 20 MHz channel: Burst length ≥ 250 μ s \pm (Accuracy of reference frequency \times Carrier frequency + 16) Hz	
	Residual Vector Error	Channel Estimation: SEQ, Phase Tracking: On, Amplitude Tracking: Off, Burst signal 5835 MHz to 5925 MHz (channel No. 167 to 185): $\leq 1.5\%$ (rms) 300 MHz to 862 MHz: $\leq 0.5\%$ (rms)	
	Center Frequency Leakage Floor	≤ -50 dBc (nom.)	
Amplitude Measurement	Tx Power Accuracy (This is found from root sum of squares (RSS) of absolute amplitude accuracy and in-band frequency characteristics of main frame.)	Input attenuator ≥ 10 dB ± 0.6 dB (Preamp Off, or Preamp not installed) ± 1.1 dB (Preamp On)	5835 MHz to 5925 MHz (Channel No.: 167 to 185) ± 1.9 dB (at Preamp Off, or Preamp not installed.) 300 MHz to 862 MHz ± 0.7 dB (Preamp Off, or Preamp not installed)
Standard		IEEE 802.11a	
Modulation/ Frequency Measurements	Frequency Range	5180 MHz to 5320 MHz (channel No. 36 to 64) 5500 MHz to 5700 MHz (channel No. 100 to 140) 5745 MHz to 5825 MHz (channel No. 149 to 165)	
	Measurement Level Range	-15 to +30 dBm (MS269xA Preamp Off, or Preamp not installed) -12 to +30 dBm (MS2830A Preamp Off, or Preamp not installed, MS2830A-045 not installed) -6 to +30 dBm (MS2830A Preamp Off, or Preamp not installed, MS2830A-045 installed) -30 to +10 dBm (Preamp On)	
	Carrier Frequency Accuracy	Burst length ≥ 250 μ s \pm (Accuracy of reference frequency \times Carrier frequency + 16) Hz	
	Residual Vector Error	Channel Estimation: SEQ, Phase Tracking: On, Amplitude Tracking: Off, Burst signal $\leq 1.5\%$ (rms) $\leq 1.6\%$ (rms) (Preamp Off)	
	Center Frequency Leakage Floor	≤ -50 dBc (nom.)	
Amplitude Measurement	Tx Power Accuracy (This is found from root sum of squares (RSS) of absolute amplitude accuracy and in-band frequency characteristics of main frame.)	Input attenuator ≥ 10 dB ± 0.6 dB (Preamp Off, or Preamp not installed) ± 1.1 dB (Preamp On)	± 1.9 dB (Preamp Off, or Preamp not installed)
Standard		IEEE 802.11b, IEEE 802.11g ERP-DSSS/CCK	
Modulation/ Frequency Measurements	Frequency Range	2412 MHz to 2472 MHz (channel No.1 to 13) 2484 MHz (channel No.14)	
	Measurement Level Range	-15 to +30 dBm (MS269xA Preamp Off, or Preamp not installed) -15 to +30 dBm (MS2830A Preamp Off, or Preamp not installed, MS2830A-045 not installed) -9 to +30 dBm (MS2830A Preamp Off, or Preamp not installed, MS2830A-045 installed) -30 dBm to +10 dBm (at Preamp On)	
	Carrier Frequency Accuracy	Burst length ≥ 400 μ s \pm (Accuracy of reference frequency \times Carrier frequency + 21) Hz	
	Residual Vector Error	Specify filter with same characteristics as used for measurement signal, Burst signal $\leq 1.2\%$ (rms) $\leq 1.9\%$ (rms) (Preamp Off)	
	Center Frequency Leakage Floor	≤ -50 dBc (nom.)	
Amplitude Measurement	Tx Power Accuracy (This is found from root sum of squares (RSS) of absolute amplitude accuracy and in-band frequency characteristics of main frame.)	Input attenuator ≥ 10 dB ± 0.6 dB (Preamp Off, or Preamp not installed) ± 1.1 dB (Preamp On)	± 0.6 dB (Preamp Off, or Preamp not installed)
Standard		IEEE 802.11g ERP-OFDM	
Modulation/ Frequency Measurements	Frequency Range	2412 MHz to 2472 MHz (channel No.1 to 13) 2484 MHz (channel No.14)	
	Measurement Level Range	-15 to +30 dBm (MS269xA Preamp Off, or Preamp not installed) -15 to +30 dBm (MS2830A Preamp Off, or Preamp not installed, MS2830A-045 not installed) -9 to +30 dBm (MS2830A Preamp Off, or Preamp not installed, MS2830A-045 installed) -30 to +10 dBm (Preamp On)	
	Carrier Frequency Accuracy	Burst length ≥ 250 μ s \pm (Accuracy of reference frequency \times Carrier frequency + 13) Hz	
	Residual Vector Error	Channel Estimation: SEQ, Phase Tracking: On, Amplitude Tracking: Off, Burst signals $\leq 1.2\%$ (rms) $\leq 1.2\%$ (rms) (Preamp Off)	
	Center Frequency Leakage Floor	≤ -50 dBc (nom.)	
Amplitude Measurement	Tx Power Accuracy (This is found from root sum of squares (RSS) of absolute amplitude accuracy and in-band frequency characteristics of main frame.)	Input attenuator ≥ 10 dB ± 0.6 dB (Preamp Off, or Preamp not installed) ± 1.1 dB (Preamp On)	± 0.6 dB (Preamp Off, or Preamp not installed)

MX2690xxA series Measurement Software

WLAN (802.11) Measurement Software MX269028A

MS269xA

MS2830A

802.11ac (80 MHz) Measurement Software MX269028A-001

802.11ac (160 MHz) Measurement Software MX269028A-002 (Continued)

Signal Analyzer		MS269xA	MS2830A
Standard		IEEE 802.11j	
Modulation/ Frequency Measurements	Frequency Range	4920 MHz to 4980 MHz	
	Measurement Level Range	-15 to +30 dBm (MS269xA Preamp Off, or Preamp not installed) -12 to +30 dBm (MS2830A Preamp Off, or Preamp not installed, MS2830A-045 not installed) -6 to +30 dBm (MS2830A Preamp Off, or Preamp not installed, MS2830A-045 installed) -30 to +10 dBm (Preamp On)	
	Carrier Frequency Accuracy	Burst length ≥ 1 ms (Channel Bandwidth: 5 MHz), or Burst length ≥ 500 μ s (Channel Bandwidth: 10 MHz), Burst length ≥ 250 μ s (Channel Bandwidth: 20 MHz) \pm (Accuracy of reference frequency \times Carrier frequency + 16) Hz	
Modulation/ Frequency Measurements	Residual Vector Error	Channel Estimation: SEQ, Phase Tracking: On, Amplitude Tracking: Off, Burst signal $\leq 1.5\%$ (rms) $\leq 1.6\%$ (rms) (Preamp Off)	
	Center Frequency Leakage Floor	≤ -50 dBc (nom.)	
Amplitude Measurement	Tx Power Accuracy (This is found from root sum of squares (RSS) of absolute amplitude accuracy and in-band frequency characteristics of main frame.)	Input attenuator ≥ 10 dB ± 0.6 dB (Preamp Off, or Preamp not installed) ± 1.1 dB (Preamp On)	± 1.9 dB (Preamp Off, or Preamp not installed)

802.11ac (80 MHz) Measurement software MX269028A-001 (MS2830A Option)

802.11ac (160 MHz) Measurement software MX269028A-002 (MS269xA Option)

Signal Analyzer		MS269xA	MS2830A	
Standard		IEEE 802.11ac		
Modulation/ Frequency Measurements	Frequency Measurements	20 MHz Channel/40 MHz Channel 5180 MHz to 5320 MHz (channel No. 36 to 64) 5500 MHz to 5700 MHz (channel No. 100 to 140) 5745 MHz to 5825 MHz (channel No. 149 to 165) 80 MHz Channel/160 MHz Channel 5180 MHz to 5825 MHz (channel No. 36 to 165)		
		Measurement Level Range	20 MHz Channel/40 MHz Channel -15 to +30 dBm (MS269xA Preamp Off, or Preamp not installed) -15 to +30 dBm (MS2830A Preamp Off, or Preamp not installed, MS2830A-045 not installed) -9 to +30 dBm (MS2830A Preamp Off, or Preamp not installed, MS2830A-045 installed) -30 to +10 dBm (Preamp On) 80 MHz Channel/160 MHz Channel -10 to +30 dBm (MS269xA Preamp Off, or Preamp not installed) -10 to +30 dBm (MS2830A Preamp Off, or Preamp not installed, MS2830A-045 not installed) -4 to +30 dBm (MS2830A Preamp Off, or Preamp not installed, MS2830A-045 installed) -20 to +10 dBm (Preamp On)	
	Carrier Frequency Accuracy		20 MHz channel	Burst length ≥ 250 μ s \pm (Accuracy of reference frequency \times Carrier frequency + 16) Hz
		40 MHz channel	Burst length ≥ 250 μ s \pm (Accuracy of reference frequency \times Carrier frequency + 102) Hz	
		80 MHz channel	Burst length ≥ 250 μ s \pm (Accuracy of reference frequency \times Carrier frequency + 102) Hz	
		160 MHz channel	Burst length ≥ 250 μ s \pm (Accuracy of reference frequency \times Carrier frequency + 102) Hz	
	Residual Vector Error	20 MHz channel	Channel Estimation: SEQ, Phase Tracking: On, Amplitude Tracking: Off, Burst signal $\leq 0.7\%$ (rms) (Preamp Off) $\leq 0.9\%$ (rms) (Preamp Off) $\leq 0.9\%$ (rms) (Preamp On)	
		40 MHz channel	Channel Estimation: SEQ, Phase Tracking: On, Amplitude Tracking: Off, Burst signal $\leq 0.8\%$ (rms) (Preamp Off) $\leq 1.0\%$ (rms) (Preamp Off) $\leq 1.0\%$ (rms) (Preamp On)	
		80 MHz channel	Channel Estimation: SEQ, Phase Tracking: On, Amplitude Tracking: Off, Burst signal $\leq 0.9\%$ (rms) (Preamp Off) $\leq 1.1\%$ (rms) (Preamp Off) $\leq 1.1\%$ (rms) (Preamp On)	
		160 MHz channel	Channel Estimation: SEQ, Phase Tracking: On, Amplitude Tracking: Off, Burst signal $\leq 1.5\%$ (rms) (Preamp Off) $\leq 1.7\%$ (rms) (Preamp On)	
Center Frequency Leakage Floor		≤ -50 dBc (nom.)		
Amplitude Measurement	Tx Power Accuracy (This is found from root sum of squares (RSS) of absolute amplitude accuracy and in-band frequency characteristics of main frame.)	20 MHz channel	Input attenuator ≥ 10 dB ± 0.6 dB (Preamp Off, or Preamp not installed) ± 1.1 dB (Preamp On)	± 1.9 dB (Preamp Off, or Preamp not installed)
		40 MHz channel	Input attenuator ≥ 10 dB ± 0.7 dB (Preamp Off, or Preamp not installed) ± 1.1 dB (Preamp On)	± 2.0 dB (Preamp Off, or Preamp not installed)
		80 MHz channel	Input attenuator ≥ 10 dB ± 1.2 dB (Preamp Off, or Preamp not installed) ± 1.6 dB (Preamp On)	± 3.2 dB (Preamp Off, or Preamp not installed)
		160 MHz channel	Input attenuator ≥ 10 dB ± 1.3 dB (Preamp Off, or Preamp not installed) ± 1.7 dB (Preamp On)	—

MX2690xxA series Measurement Software

WLAN (802.11) Measurement Software MX269028A
802.11ac (80 MHz) Measurement Software MX269028A-001
802.11ac (160 MHz) Measurement Software MX269028A-002 (Continued)

MS269xA

MS2830A

Measurement Functions

Parameter Setting

Standard-compliant parameters as well as frequency/level are set at the following screen.

Parameters other than numerical values are set easily by selecting pull-down menus.

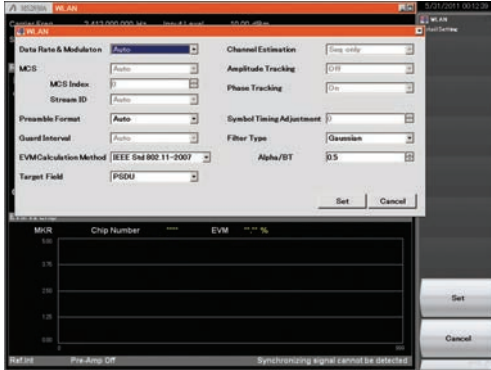

Modulation Analysis Function

Summary

This displays detected parameters as well as numerical results. The dispersion of RF characteristics is measured easily using simultaneous display of maximum and average values.

MX269028A (IEEE 802.11n, 11p, 11a, 11b, 11g, 11j)



- Frequency Error
- Symbol Clock Error/Chip Clock Error
- Transmit Power
- EVM [rms] (Data EVM, Pilot EVM, SIG EVM (rms), L-SIG EVM (rms), HT-SIG EVM (rms))
- EVM [Peak] (Symbol Number, Subcarrier Number/Chip Number)
- Quadrature Error
- IQ Gain Imbalance
- Center Frequency Leakage
- Phase Error
- Magnitude Error
- IQ Origin Offset
- Detect Parameter (Data Rate, Modulation Method, Symbol Length/Chip Length, Preamble, MCS Index, Stream ID, Symbol Length, GI)

MX269028A-001/002 (IEEE 802.11ac)



- Frequency Error
 - Symbol Clock Error
 - Transmit Power
 - EVM [rms] (Data EVM, Pilot EVM, L-SIG EVM (rms), VHT-SIG-A EVM (rms), VHT-SIG-B EVM (rms))
 - EVM [Peak] (Symbol Number, Subcarrier Number)
 - Quadrature Error*
 - IQ Gain Imbalance*
 - Center Frequency Leakage
 - Detect Parameter (MCS Index, Stream ID, Symbol Length, GI)
- *: Exclude Channel Bandwidth 160 MHz setting

Constellation/Numerical Result

The Constellation/numerical value results are displayed at the top of the screen. The Constellation screen displays IQ coordinates and subcarrier information for the position selected by the marker. The dispersion of characteristics is measured easily using simultaneous display of maximum and average values.

MX269028A (IEEE 802.11n, 11p, 11a, 11b, 11g, 11j)



Measurement signal:

IEEE 802.11n, 11p, 11a, 11g (ERP-OFDM, DSSS-OFDM), 11j

- Frequency Error
- Symbol Clock Error
- Transmit Power
- EVM [rms/peak]
- Center Frequency Leakage

MX2690xxA series Measurement Software

WLAN (802.11) Measurement Software MX269028A
 802.11ac (80 MHz) Measurement Software MX269028A-001
 802.11ac (160 MHz) Measurement Software MX269028A-002 (Continued)

MS269xA MS2830A



EVM vs. Subcarrier

This displays the EVM vs. Subcarrier graphs (horizontal axis: Subcarrier, vertical axis: EVM) at the bottom of the screen. The EVM calculation method can be selected from:

- Averaged: Mean value of all analysis symbols
- Each: Symbol value selected by the marker

It is useful for checking in-band interference signals.



EVM vs. Symbol

This displays the EVM vs. Symbol graphs (horizontal axis: Symbol, vertical axis: EVM) at the bottom of the screen.

It is useful for checking characteristics in the time direction and faults at a specific symbol.



EVM vs. Chip

This displays the EVM vs. Chip graphs (horizontal axis: Chip, vertical axis: EVM) at the bottom of the screen.

It is useful for checking characteristics in the time direction and faults at a specific chip.

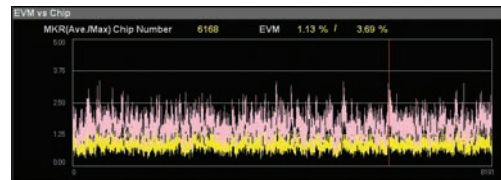

Phase Error vs. Chip

This displays the Phase Error vs. Chip graphs (horizontal axis: Chip, vertical axis: Phase Error) at the bottom of the screen.

It is useful for checking a phase change in time direction.

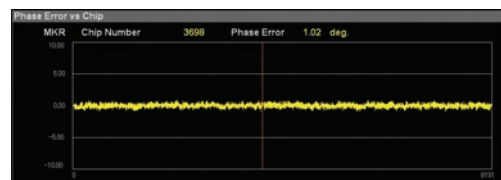

Measurement signal: IEEE 802.11b, 11g (ERP-DSSS/CCK)

- Frequency Error
- Chip Clock Error
- Transmit Power
- EVM [rms/peak]
- IQ Origin Offset

MX269028A-001/002 (IEEE 802.11ac)



Measurement Signal: IEEE 802.11ac

- Frequency Error
- Symbol Clock Error
- Transmit Power
- EVM (rms/Peak)
- Center Frequency Leakage

MX2690xxA series Measurement Software

WLAN (802.11) Measurement Software MX269028A
 802.11ac (80 MHz) Measurement Software MX269028A-001
 802.11ac (160 MHz) Measurement Software MX269028A-002 (Continued)

MS269xA MS2830A

• Spectral Flatness

A graph of Amplitude vs. Subcarrier (horizontal axis: Subcarrier, vertical axis: Amplitude), Phase vs. Subcarrier (horizontal axis: Subcarrier, vertical axis: Phase) and Group Delay vs. Subcarrier (horizontal axis: Subcarrier, vertical axis: Group Delay) can be selected.

It is useful for checking frequency response (Amplitude, Phase, Group Delay).

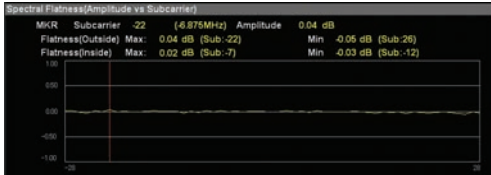

• Eye Diagram

This displays the I/Q vs. Chip graphs (horizontal axis: Chip, vertical axis: I/Q) at the bottom of the screen.

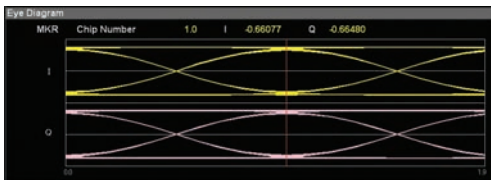

Power vs. Time Function*

*: Supports IEEE 802.11n/p/a/b/g/j

• Numerical Results

The numerical results are displayed at the top of the screen.

- Transmit Power
- Power Flatness Max
- Carrier Off Power
- On/Off Ratio
- Peak PSD
- Transient Time
 - Power-on Ramp
 - Power-off Ramp

The dispersion of characteristics is measured easily using simultaneous display of maximum and average values.



• Burst

This displays the Power vs. Time graph (horizontal axis: Time, vertical axis: Power) for one burst waveform at the bottom of the screen.

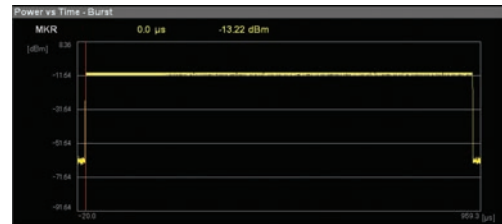

• Transient

This zoom-displays the rising and falling edges of a burst waveform (horizontal axis: Time, vertical axis: Power). Displayed time scale is adjustable.

It is useful for checking power-on ramp and power-down ramp of burst signal.

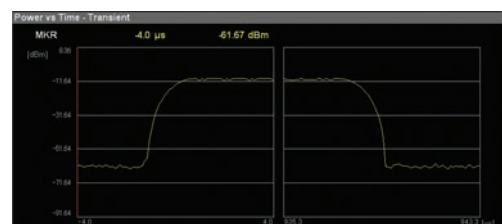

MX2690xxA series Measurement Software

WLAN (802.11) Measurement Software MX269028A
802.11ac (80 MHz) Measurement Software MX269028A-001
802.11ac (160 MHz) Measurement Software MX269028A-002 (Continued)

MS269xA

MS2830A

Powerful Capture & Replay Function for Fault Analysis*1

When faults are detected on-site, this function captures*2 and saves*2 signals to a file for later replay by the WLAN Measurement Software to troubleshoot items, such as EVM measurements.

*1: This function is not supported when the MX269028A-002 (only for MS269xA) is installed and the channel bandwidth is set to 160 MHz.

*2: Data for 1 burst signal

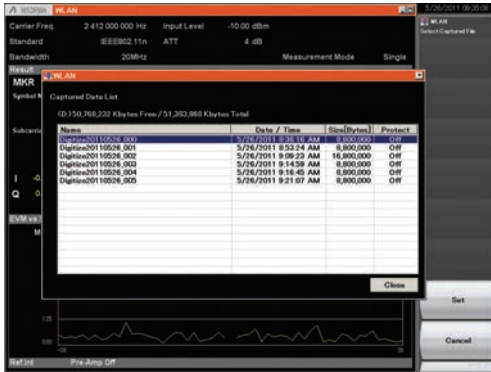

Example of R&D use

- Save data for comparing each DUT test version
- Supports comparison of retrofitting improvement effects

Example of production line use

- Save delivery inspection data
- Supports rechecking of performance data for troubleshooting post-delivery faults

MX2690xxA series Measurement Software

WLAN (802.11) Measurement Software MX269028A
802.11ac (80 MHz) Measurement Software MX269028A-001
802.11ac (160 MHz) Measurement Software MX269028A-002 (Continued)

MS269xA

MS2830A

MS269xA/MS2830A Main Frame Measurement Functions

The following measurements are performed by calling the main-frame spectrum analyzer functions. These functions prepare each measurement standard templates.

- Adjacent Channel Leakage Power (ACP)
- Occupied Bandwidth (OBW)
- Spectrum Emission Mask (SEM)
- Spurious Emission

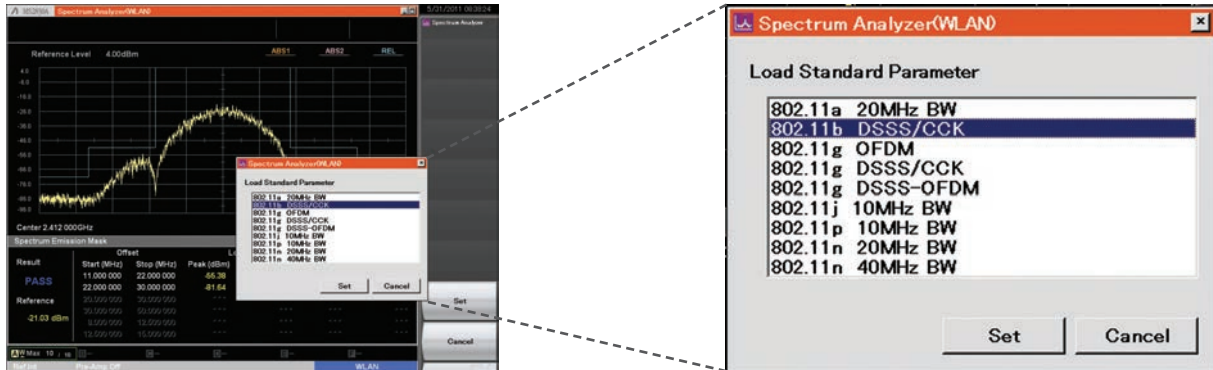

ex.) Template of Spectrum Emission Mask (SEM)

Each Measurement Standard Templates

Standard	Bandwidth	Supported Template			
		ACP	OBW	SEM	Spurious
IEEE 802.11n	20 MHz	✓ TELEC T403	✓ TELEC T403 ✓ ETSI	✓ IEEE ✓ ETSI	✓ TELEC T403 ✓ ETSI ✓ FCC
	40 MHz	✓ TELEC T403	✓ TELEC T403 ✓ ETSI	✓ IEEE ✓ ETSI	✓ TELEC T403 ✓ ETSI ✓ FCC
IEEE 802.11p	5 MHz	—	✓ ETSI	✓ ETSI	✓ TELEC T405 ✓ ETSI ✓ FCC
	10 MHz	—	✓ ETSI	✓ ETSI	✓ TELEC T405 ✓ ETSI ✓ FCC
	20 MHz	✓ TELEC T403	✓ TELEC T403 ✓ ETSI	✓ ETSI	✓ TELEC T403 ✓ ETSI ✓ FCC
IEEE 802.11a	—	✓ TELEC T403	✓ TELEC T403 ✓ ETSI	✓ IEEE ✓ ETSI	✓ TELEC T403 ✓ ETSI ✓ FCC
IEEE 802.11b	—	—	✓ TELEC T401	✓ IEEE	✓ TELEC T401 ✓ ETSI
IEEE 802.11g ERP-DSSS/CCK	—	—	✓ TELEC T401	✓ IEEE	✓ TELEC T401 ✓ ETSI
IEEE 802.11g ERP-OFDM	—	—	✓ TELEC T401 ✓ ETSI	✓ IEEE ✓ ETSI	✓ TELEC T401 ✓ ETSI
IEEE 802.11g DSSS-OFDM	—	—	✓ TELEC T401 ✓ ETSI	✓ IEEE ✓ ETSI	✓ TELEC T401 ✓ ETSI
IEEE 802.11j	5 MHz	—	✓ ETSI	✓ ETSI	✓ TELEC T405
	10 MHz	—	✓ ETSI	✓ IEEE ✓ ETSI	✓ TELEC T405
	20 MHz	✓ TELEC T403	✓ TELEC T403 ✓ ETSI	✓ IEEE ✓ ETSI	✓ TELEC T403
IEEE 802.11ac	20 MHz	—	✓ ETSI	✓ IEEE ✓ ETSI	—
	40 MHz	—	✓ ETSI	✓ IEEE ✓ ETSI	—
	80 MHz	—	✓ ETSI	✓ IEEE	—
	160 MHz	—	✓ ETSI	✓ IEEE	—

The W-CDMA BS Measurement Software MX269030A is targeted at manufacturing of W-CDMA/HSPA base stations, repeaters, and power amplifiers. It supports measurement of the RF Tx characteristics of high-speed W-CDMA/HSPA downlink signals. Installation in the MS269xA or MS2830A supports fast, high-accuracy measurements to cut tact times.

Functions Supporting Manufacturing of W-CDMA/HSPA Base Stations

Supports fast, high-accuracy modulation analyses and spectrum measurements for manufacturing W-CDMA/HSPA base stations, repeaters, and power amplifiers.

■ Modulation Analysis

- Mean Power
- CPICH Power
- Carrier Frequency Error
- Vector Error (EVM) [Peak/rms]
- Peak Code Domain Error (PCDE)
- IQ Origin Offset
- Relative Code Domain Error (RCDE)
- Scrambling Code
- PCDE CH/SF/Slot
- Constellation (all codes)
- Code Domain Graph

■ Spectrum

- Occupied Bandwidth (OBW)
- Adjacent Channel Leakage Power (ACLR)
- Spectrum Emission Mask (SEM)

Specifications

The specification is the value after 30-minute warm-up at a constant ambient temperature.

The specifications are defined under the following condition unless otherwise specified.

Attenuator mode: Mechanical Attenuator Only (MS2830A only)

Signal Analyzer		MS269xA	MS2830A
Common Specifications	Target Signal	W-CDMA/HSPA Downlink	
	Frequency Range	400 MHz to 3 GHz	
	Input Level Setting Range	-24 to +30 dBm (Preamp Off, or Preamp not installed)	
Modulation/ Frequency Measurement	Carrier Frequency Measurement Accuracy	Input level range: Input Level to Input Level -10 dB (Input Level \geq -4 dBm), for 1 wave multiplexed signals with EVM = 1%	
		\pm (Accuracy of reference frequency \times Carrier frequency + 4 Hz)	\pm (Accuracy of reference frequency \times Carrier frequency + 6 Hz)
	Residual Vector Error	Input level range: Input Level to Input Level -10 dB (Input Level \geq -4 dBm), for 64DPCH multiplexed signals conforming to 3GPP TS 25.141 TestModel1	
		\leq 1.0% (rms)	\leq 1.3% (rms)
	Code Domain Power Relative Value Accuracy	Input level range: Input Level to Input Level -10 dB (Input Level \geq -4 dBm), for signals conforming to 3GPP TS 25.141 TestModel2	
	\pm 0.02 dB (Code Domain Power \geq -10 dBc) \pm 0.10 dB (Code Domain Power \geq -30 dBc)	\pm 0.02 dB (Code Domain Power \geq -10 dBc) \pm 0.15 dB (Code Domain Power \geq -30 dBc)	
	Residual Code Domain Error	Input level range: Input Level to Input Level -10 dB (Input Level \geq -4 dBm), for signals conforming to 3GPP TS 25.141 TestModel3	
		\leq -50 dB	\leq -47 dB
	Code Domain Error Accuracy	Input level range: Input Level to Input Level -10 dB (Input Level \geq -4 dBm), for signals conforming to 3GPP TS 25.141 TestModel3, with code domain error of -40 dBc	
		\pm 0.75 dB	\pm 0.79 dB
Amplitude Measurement	Tx Power Measurement Accuracy (This is found from root sum of squares (RSS) of absolute amplitude accuracy and in-band frequency characteristics of main frame.)	At 18° to 28°C, after calibration, for signals with the input level range of Input Level to Input Level -10 dB (Input Level \geq -4 dBm)	
		\pm 0.6 dB	
Spectrum Measurement	Occupied Bandwidth Measurement	Attained with 99% method on spectrum waveforms attained by FFT calculation.	
	Adjacent Channel Leakage Power Measurement	Performs RRC filter processing ($\alpha = 0.22$) on spectrum waveforms attained by FFT calculation. 18° to 28°C, for single carrier, Input Level \geq -4 dBm	
		-65 dB (5 MHz offset) -66 dB (10 MHz offset)	-64 dB (5 MHz offset, nom.) -65 dB (10 MHz offset, nom.)
	Spectrum Emission Mask Measurement	18° to 28°C, for single carrier, Input Level \geq -4 dBm	
		-78 dB/30 kHz (\geq 2.515 MHz offset)	-77 dB/30 kHz (\geq 2.515 MHz offset, nom.)

Measurement Functions

- Batch Modulation Analysis and Spectrum Measurements**

Measures all modulation analysis items (Mean Power, Carrier Frequency Error/EVM/PCDE, etc.), and spectrum measurements (ACLR/OBW/SEM) in about 100 ms to cut tact times.

- Convenient Graph Display**

Supports convenient graph function for checking signals to troubleshoot unexpected problems on production lines, etc., as quickly as possible.

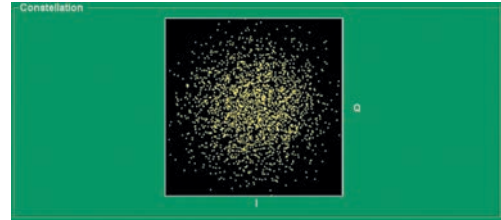

Constellation (all codes)

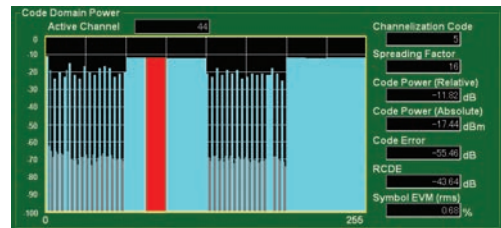

Code Domain Display

MX2690xxA series Measurement Software

Wireless Network Device Software MX283027A WLAN Test Software MX283027A-001 Bluetooth Test Software MX283027A-002

MS2830A

The Wireless Network Device Software MX283027A, WLAN Test Software MX283027A-001, and *Bluetooth* Test Software MX283027A-002 are for measuring the RF characteristics of wireless terminals and devices.

Installing these options in the MS2830A Signal Analyzer with MS2830A-020/021 Vector Signal Generator option supports TRx tests of WLAN and *Bluetooth* devices/modules using one measurement unit.

Shortening test times by eliminating measurement screens helps facilitate high-speed, high-accuracy measurements on production lines.

Features

- One software package supporting IEEE 802.11n/a/b/g (MX283027A-001)
- One software package supporting Basic Rate/Enhanced Data Rate/*Bluetooth* Low Energy (MX283027A-002)
- One hardware unit supporting high-speed TRx measurements (with vector signal generation option (MS2830A-020/021))

Points for High-speed Measurement

- Eliminates measurement screens to cut measurement time
- Batch processing minimizes signal loading and processing of multiple measurements
- Simplifies batch measurements by remote commands

WLAN High-speed TRx Characteristics Measurements

• WLAN Test Software* MX283027A-001

One unit supports high-speed measurements of TRx characteristics of devices and modules based on WLAN standards.

Installing the Vector Signal Generator option (MS2830A-020/021) outputs WLAN signals and measures Rx characteristics.

No measurement screen is displayed at the main frame.

Measurement setting and execution, and reading of numerical results are under remote control.

■ Measurement Signals

- IEEE 802.11n (HT-Mixed, HT-Greenfield)
- IEEE 802.11a
- IEEE 802.11b
- IEEE 802.11g ERP-DSSS/CKK
- IEEE 802.11g ERP-OFDM

■ Tx Characteristics Tests

Batch measurements are executed to measure the following items and read the numerical results by remote control.

- Modulation Analysis
- Tx Power Measurements
- Transmit Spectrum Mask Measurements
- Occupied Bandwidth Measurements

■ Rx Characteristics Tests

Installing the Vector Signal Generator option (MS2830A-020/021) supports the following WLAN signal outputs:

- Preinstalled WLAN Waveform Pattern (IEEE 802.11a/b/g)
- WLAN IQproducer Generation Waveform Pattern* (IEEE 802.11n/p/a/b/g/j)

Numerical Value
Modulation Analysis
Vector Error (EVM) [rms/Peak]
Vector Error (EVM) [rms/Peak] pass/fail judgement result
Frequency Error
Frequency Error pass/fail judgement result
Center Frequency Leakage Power
Center Frequency Leakage Power pass/fail judgement result
IQ Offset
IQ Offset pass/fail judgement result
Spectrum Flatness pass/fail judgement result
IQ Gain Imbalance
Quadrature Error

Numerical Value
Symbol Clock Error
Symbol Clock Error pass/fail judgement result
Chip Clock Error
Chip Clock Error pass/fail judgement result
Count of modulation accuracy measurements
Tx Power Measurement
Tx Power
Tx Power pass/fail judgement result
Peak Power Spectrum Density (PSD)
Peak Power Spectrum Density (PSD) pass/fail judgement result
Burst waveform rise time
Burst waveform fall time
Rise and fall time pass/fail judgement result
Count of transmit power measurements
Transmit Spectrum Mask
Peak PSD of reference channel
Absolute value of spectrum density at frequency where margin from limit line becomes minimum within offset frequency range [positive/negative side]
Margin from limit line at frequency where margin is minimum for limit line within offset frequency range [positive/negative side]
Frequency where margin from limit line becomes minimum within offset frequency range [positive/negative side]
Pass/fail judgement result within offset frequency range
Count of Tx spectrum mask measurements
Absolute value of spectrum density at start frequency of offset [positive/negative side]
Absolute value of spectrum density at end frequency of offset [positive/negative side]
Occupied Bandwidth Measurement
Occupied Bandwidth
Occupied Bandwidth pass/fail judgement result
Count of Occupied Bandwidth measurements

*: MX283027A-001 includes WLAN IQproducer MX269911A (Cannot order MX283027A-001 and MX269911A at same time).

Example of WLAN Module TRx Characteristics Measurement System

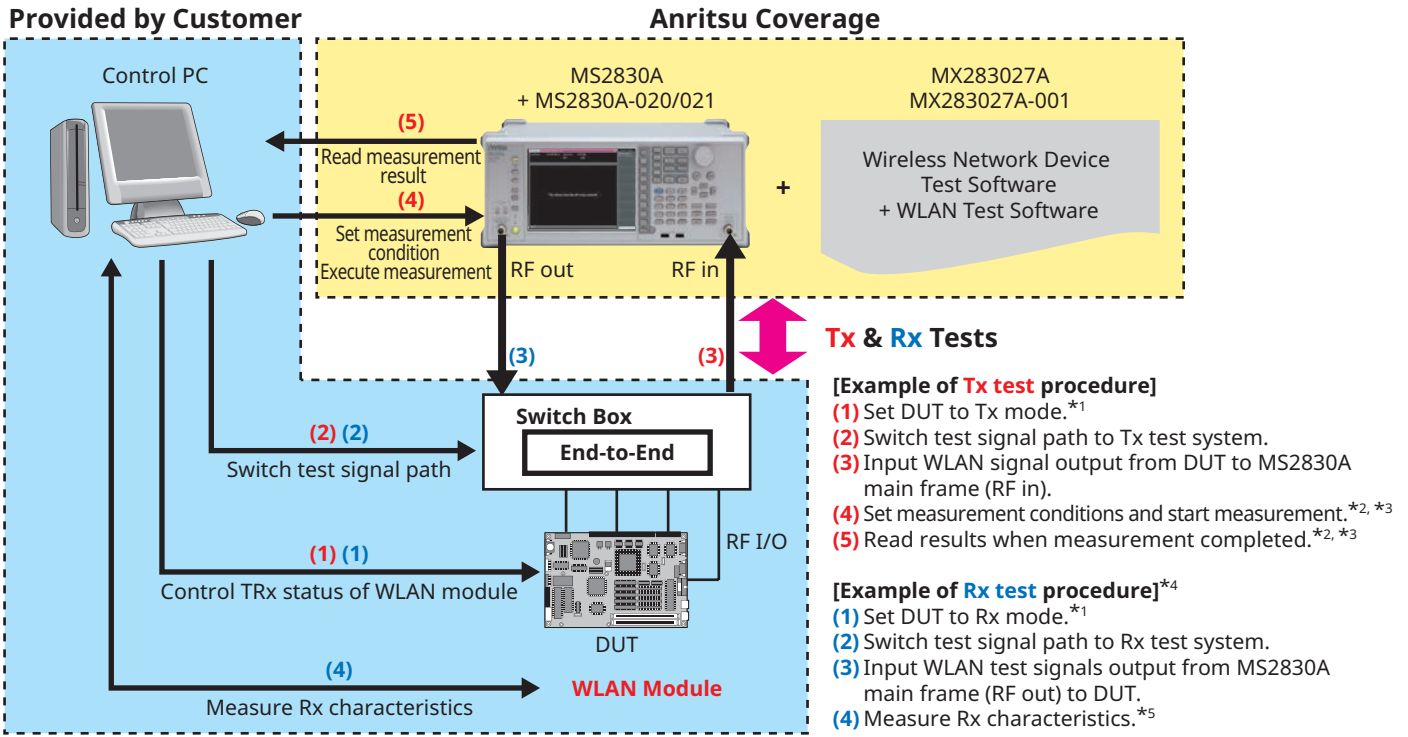

- *1: Direct control measurements
Measure TRx characteristics after setting DUT to Tx or Rx mode using control software provided by chipset maker. Please prepare the Control software for the DUT.
- *2: Measurement settings and execution, and reading of numerical results are executed by remote control.
- *3: No measurement screen displayed on main frame.
- *4: Installing Vector Signal Generator option (MS2830A-020/021) outputs WLAN signals.
- *5: Evaluate Rx characteristics with DUT or control PC.

Bluetooth High-speed TRx Characteristics Measurements

Bluetooth Test Software MX283027A-002

One unit supports measurement of high-speed TRx characteristics of *Bluetooth* devices and modules. Installing the Vector Signal Generator option (MS2830A-020/021) outputs *Bluetooth* signals and measures Rx characteristics.

No measurement screen is displayed on the main frame.
 Measurement settings and execution, and reading of numerical results are executed by remote control.

Measurement Signals

- Basic Rate
- Enhanced Data Rate
- *Bluetooth* Low Energy

Tx Characteristics Tests

Batch measurements are executed to measure the following items and read the numerical results by remote control.

- Output Power Measurements
- Modulation Characteristics Measurements
- ICFT Measurements
- Carrier Frequency Drift
- EDR Frequency Stability/Modulation Accuracy Measurements
- EDR Relative Tx Power Measurements
- EDR Differential Phase Decode Measurements
- Demodulation Data Measurements

Rx Characteristics Tests

Installing the Vector Signal Generator option (MS2830A-020/021) supports the following *Bluetooth* signal outputs:

Preinstalled Bluetooth Waveform Pattern

Packet format
DH1, DH3, DH5 [Clean/Dirty/Dirty withFM]
DH3_3SlotOff, DH5_5SlotOff
2-DH1, 2-DH3, 2-DH5 [Clean/Dirty/Dirty withFM]
3-DH1, 3-DH3, 3-DH5 [Clean/Dirty/Dirty withFM]
2-DH3_3SlotOff, 2-DH5_5SlotOff
3-DH3_3SlotOff, 3-DH5_5SlotOff
BLE, BLE_Dirty, BLE_Dirty_withFM, BLE_CRC_corrupted
No packet format
GFSK-PN9, GFSK-PN15
PI_4_DQPSK-PN9, PI_4_DQPSK-PN15
8DPSK-PN9, 8DPSK-PN15
GMSK-PN15_BLE

Tx Characteristics Measurement Numerical Results
Output Power Measurements
GFSK average power, peak power
GFSK average power pass/fail judgement result
Count of output power measurements
Modulation Characteristics Measurements
∠f1 (payload data: 11110000/00001111) Average frequency error
∠f2 (payload data: 10101010/01010101) Average frequency error
∠f1 maximum frequency error
∠f2 maximum frequency error
∠f2 maximum frequency error > lower limit ratio
∠f2 average frequency error/∠f1 average frequency error
∠f1 average frequency error pass/fail judgement result
∠f2 maximum frequency error > Lower limit ratio pass/fail judgement result
∠f2 average frequency error/∠f1 average frequency error pass/fail judgement result
Count of modulation characteristics measurements
Initial Center Frequency Tolerance (ICFT) Measurements
ICFT
ICFT pass/fail judgement result
Count of ICFT measurements
Carrier Frequency Drift Measurements
Frequency drift
Maximum drift rate
Frequency drift pass/fail judgement result
Maximum drift rate pass/fail judgement result
Count of carrier frequency drift measurement

Tx Characteristics Measurement Numerical Results
EDR Frequency Stability/Modulation Accuracy Measurements
Frequency error
Differential vector error (DEVM) [RMS value/peak value/99% value]
Frequency error pass/fail judgement result
Differential vector error (DEVM) pass/fail judgement result
Count of EDR frequency stability/modulation accuracy measurements
EDR Relative Tx Power Measurements
GFSK average power
DPSK average power
Relative power (difference between GFSK and DPSK average power)
Relative power pass/fail judgement result
Count of EDR relative Tx power measurements

Rx Characteristics Measurement Numerical Results
EDR Differential Phase Encoding Measurements
Bit error rate (BER)
Bit error
Packet error rate (PER)
Packet error rate (PER) pass/fail judgement result
Count of EDR differential phase encoding measurements
Demodulation Data Measurements
Packet type
Payload length
Payload

Example of Bluetooth Module TRx Characteristics Measurement System

Provided by Customer

Anritsu Coverage

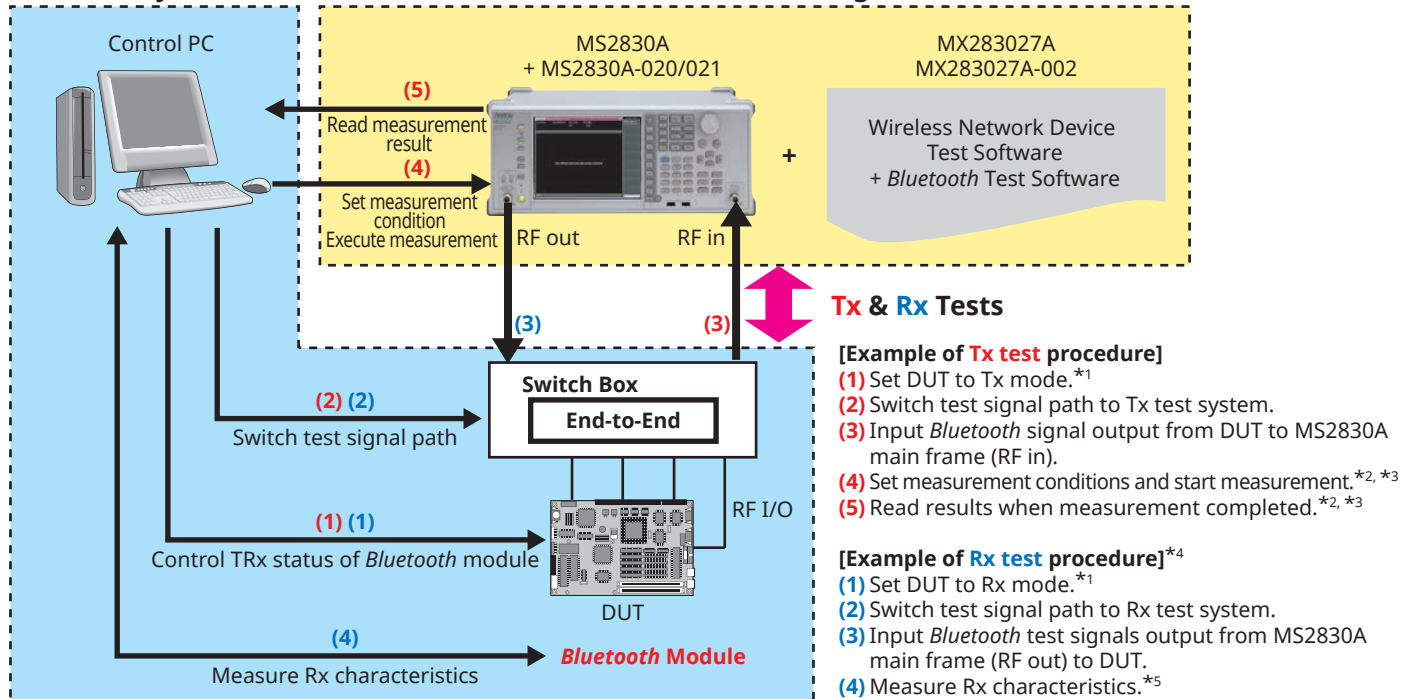

*1: Direct control measurements

Measure TRx characteristics after setting DUT to Tx or Rx mode using control software provided by chipset maker. Please prepare the Control software for the DUT.

*2: Measurement settings and execution, and reading of numerical results are executed by remote control.

*3: No measurement screen displayed on main frame.

*4: Installing Vector Signal Generator option (MS2830A-020/021) outputs Bluetooth signals.

*5: Evaluate Rx characteristics with DUT or control PC.

MX2690xxA series Measurement Software

Wireless Network Device Software MX283027A

MS2830A

WLAN Test Software MX283027A-001

Bluetooth Test Software MX283027A-002 (Continued)

Specifications

• WLAN Test Software MX283027A-001

The specification is the value after 30-minute warm-up at a constant ambient temperature. Typical values are for reference only and are not guaranteed. Values are guaranteed after executing CAL at 18° to 28°C, and the measured signal is within the measurement level range and is less than or equal to Input Level.

The specifications are defined under the following condition unless otherwise specified.

Attenuator mode: Mechanical Attenuator Only

Signal Analyzer		MS2830A
Standard		IEEE 802.11a
Modulation/ Frequency Measurements	Frequency Range	5180 MHz to 5320 MHz (channel No. 36 to 64) 5500 MHz to 5700 MHz (channel No. 100 to 140) 5745 MHz to 5825 MHz (channel No. 149 to 165)
	Measurement Level Range	-12 to +30 dBm (MS2830A-045 not installed) -6 to +30 dBm (MS2830A-045 installed)
	Carrier Frequency Accuracy	Burst length $\geq 250 \mu\text{s}$ \pm (Accuracy of reference frequency \times Carrier frequency + 16) Hz
	Residual Vector Error	Channel Estimation: SEQ, Phase Tracking: On, Amplitude Tracking: Off $\leq 1.6\%$ (rms)
	Center Frequency Leakage Floor	≤ -50 dBc (nom.)
Amplitude Measurement	Tx Power Accuracy (This is found from root sum of squares (RSS) of absolute amplitude accuracy and in-band frequency characteristics of main frame.)	Input attenuator ≥ 10 dB ± 1.9 dB
Spectrum Measurement	Tx Spectrum Mask Dynamic Range	≥ 68 dB (11 MHz Offset from carrier frequency) ≥ 68 dB (20 MHz Offset from carrier frequency) ≥ 68 dB (30 MHz Offset from carrier frequency) The dynamic range refers to the transmitted power ratio for specified frequency offset It is applied if RBW = 100 kHz and Mixer Level = -19 to -14 dBm
Standard		IEEE 802.11b, IEEE 802.11g ERP-DSSS/CCK
Modulation/ Frequency Measurements	Frequency Range	2412 MHz to 2472 MHz (channel No.1 to 13) 2484 MHz (channel No.14)
	Measurement Level Range	-15 to +30 dBm (MS2830A-045 not installed) -9 to +30 dBm (MS2830A-045 installed)
	Carrier Frequency Accuracy	Burst length $\geq 400 \mu\text{s}$ \pm (Accuracy of reference frequency \times Carrier frequency + 21) Hz
	Residual Vector Error	Specify filter with same characteristics as used for measured signal $\leq 1.9\%$ (rms)
	Center Frequency Leakage Floor	≤ -50 dBc (nom.)
Amplitude Measurement	Tx Power Accuracy (This is found from root sum of squares (RSS) of absolute amplitude accuracy and in-band frequency characteristics of main frame.)	Input attenuator ≥ 10 dB ± 0.6 dB
Spectrum Measurement	Tx Spectrum Mask Dynamic Range	≥ 68 dB (11 MHz Offset from carrier frequency) ≥ 68 dB (22 MHz Offset from carrier frequency) ≥ 68 dB (33 MHz Offset from carrier frequency) The dynamic range refers to the transmitted power ratio for specified frequency offset It is applied if RBW = 100 kHz and Mixer Level = -19 to -14 dBm
Standard		IEEE 802.11g ERP-OFDM
Modulation/ Frequency Measurements	Frequency Range	2412 MHz to 2472 MHz (channel No.1 to 13) 2484 MHz (channel No.14)
	Measurement Level Range	-15 to +30 dBm (MS2830A-045 not installed) -9 to +30 dBm (MS2830A-045 installed)
	Carrier Frequency Accuracy	Burst length $\geq 250 \mu\text{s}$ \pm (Accuracy of reference frequency \times Carrier frequency + 13) Hz
	Residual Vector Error	Channel Estimation: SEQ, Phase Tracking: On, Amplitude Tracking: Off $\leq 1.2\%$ (rms)
	Center Frequency Leakage Floor	≤ -50 dBc (nom.)
Amplitude Measurement	Tx Power Accuracy (This is found from root sum of squares (RSS) of absolute amplitude accuracy and in-band frequency characteristics of main frame.)	Input attenuator ≥ 10 dB ± 0.6 dB

MX2690xxA series Measurement Software

Wireless Network Device Software MX283027A

MS2830A

WLAN Test Software MX283027A-001

Bluetooth Test Software MX283027A-002 (Continued)

Signal Analyzer			MS2830A
Spectrum Measurement	Tx Spectrum Mask Dynamic Range		≥68 dB (11 MHz Offset from carrier frequency) ≥68 dB (20 MHz Offset from carrier frequency) ≥68 dB (30 MHz Offset from carrier frequency) The dynamic range refers to the transmitted power ratio for the specified frequency offset It is applied if RBW = 100 kHz and Mixer Level = -19 to -4 dBm
Standard			IEEE 802.11n HT Mixed, HT Greenfield (STBC, MIMO not supported), MCS = 0 to 7, 32 supported Channel Bandwidth: 20 MHz, 40 MHz
Modulation/ Frequency Measurements	Frequency Range		2.4 GHz band: 2412 MHz to 2472 MHz (channel No.1 to 13) 2484 MHz (channel No.14) 5 GHz band: 5180 MHz to 5320 MHz (channel No.36 to 64) 5500 MHz to 5700 MHz (channel No.100 to 140) 5745 MHz to 5825 MHz (channel No.149 to 165)
	Measurement Level Range		2.4 GHz band: -15 to +30 dBm (MS2830A-045 not installed) -9 to +30 dBm (MS2830A-045 installed) 5 GHz band: -12 to +30 dBm (MS2830A-045 not installed) -6 to +30 dBm (MS2830A-045 installed)
	Carrier Frequency Accuracy	20 MHz channel	Burst length ≥250 μs ± (Accuracy of reference frequency × Carrier frequency + 13) Hz (2.4 GHz band) ± (Accuracy of reference frequency × Carrier frequency + 16) Hz (5 GHz band)
		40 MHz channel	Burst length ≥250 μs ± (Accuracy of reference frequency × Carrier frequency + 62) Hz (2.4 GHz band) ± (Accuracy of reference frequency × Carrier frequency + 102) Hz (5 GHz band)
	Residual Vector Error	20 MHz channel	Channel Estimation: SEQ, Phase Tracking: On, Amplitude Tracking: Off ≤1.2% (rms) (2.4 GHz band) ≤1.6% (rms) (5 GHz band)
		40 MHz channel	Channel Estimation: SEQ, Phase Tracking: On, Amplitude Tracking: Off ≤1.6% (rms) (2.4 GHz band) ≤2.0% (rms) (5 GHz band)
Center Frequency Leakage Floor			≤-50 dBc (nom.)
Amplitude Measurement	Tx Power Accuracy (This is found from root sum of squares (RSS) of absolute amplitude accuracy and in-band frequency characteristics of main frame.)	20 MHz channel	Input attenuator ≥10 dB ±0.6 dB (2.4 GHz band) ±1.9 dB (5 GHz band)
		40 MHz channel	Input attenuator ≥10 dB ±0.8 dB (2.4 GHz band) ±2.0 dB (5 GHz band)
Spectrum Measurement	Tx Spectrum Mask Dynamic Range	20 MHz channel	2.4 GHz band: ≥68 dB (11 MHz Offset from carrier frequency) ≥68 dB (20 MHz Offset from carrier frequency) ≥68 dB (30 MHz Offset from carrier frequency) 5 GHz band: ≥68 dB (11 MHz Offset from carrier frequency) ≥68 dB (20 MHz Offset from carrier frequency) ≥68 dB (30 MHz Offset from carrier frequency) The dynamic range refers to the transmitted power ratio for the specified frequency offset It is applied if RBW = 100 kHz and Mixer Level = -19 to -14 dBm
		40 MHz channel	2.4 GHz band: ≥60 dB (21 MHz Offset from carrier frequency) ≥69 dB (40 MHz Offset from carrier frequency) ≥69 dB (60 MHz Offset from carrier frequency) 5 GHz band: ≥60 dB (21 MHz Offset from carrier frequency) ≥69 dB (40 MHz Offset from carrier frequency) ≥69 dB (60 MHz Offset from carrier frequency) The dynamic range refers to the transmitted power ratio for the specified frequency offset It is applied if RBW = 100 kHz and Mixer Level = -19 to -14 dBm

MX2690xxA series Measurement Software

Wireless Network Device Software MX283027A WLAN Test Software MX283027A-001 Bluetooth Test Software MX283027A-002 (Continued)

MS2830A

• **Bluetooth Test Software MX283027A-002**

The specification is the value after 30-minute warm-up at a constant ambient temperature. Typical values are for reference only and are not guaranteed. Values are guaranteed after executing CAL at 18° to 28°C, and the measured signal is within the measurement level range and is less than or equal to Input Level.

The specifications are defined under the following condition unless otherwise specified.

Attenuator mode: Mechanical Attenuator Only

Signal Analyzer		MS2830A
Standard		Basic Rate, <i>Bluetooth</i> Low Energy
Modulation/ Frequency Measurements	Frequency Range	2402 MHz to 2480 MHz (channel No. 0 to 78)
	Measurement Level Range	-15 to +30 dBm
	Initial Carrier Frequency Tolerance	Packet type: DH1, DH3, DH5, BLE Reference Packet Payload data: All Measurement range: 0 to ±100 kHz (nom.) Measurement accuracy: ± (Accuracy of reference frequency × Carrier frequency + 2 kHz)
	Modulation Characteristics	Packet type: DH1, DH3, DH5, BLE Reference Packet Payload data: 0xF0, 0x0F, 0xAA, 0x55 Frequency error measurement accuracy: ±1 kHz (nom.)
	Carrier Frequency Drift	Packet type: DH1, DH3, DH5, BLE Reference Packet Payload data: 0xAA, 0x55 Measurement accuracy: ±2 kHz (nom.)
Amplitude Measurement	Tx Power Accuracy (This is found from root sum of squares (RSS) of absolute amplitude accuracy and in-band frequency characteristics of main frame.)	Input attenuator ≥10 dB ±0.6 dB
Standard		Enhanced Data Rate
Modulation/ Frequency Measurements	Frequency Range	2402 MHz to 2480 MHz (channel No. 0 to 78)
	Measurement Level Range	-15 to +30 dBm
	EDR Modulation Accuracy	Packet type: 2-DH1, 2-DH3, 2-DH5, 3-DH1, 3-DH3, 3-DH5 Payload data: All DEVm floor ≤1.2% (rms)
EDR Carrier Frequency Stability	Packet type: 2-DH1, 2-DH3, 2-DH5, 3-DH1, 3-DH3, 3-DH5 Payload data: All Measurement accuracy: ± (Accuracy of reference frequency × Carrier frequency + 2 kHz)	
Amplitude Measurement	Tx Power Accuracy (This is found from root sum of squares (RSS) of absolute amplitude accuracy and in-band frequency characteristics of main frame.)	Input attenuator ≥10 dB ±0.6 dB

MX2690xxA series Measurement Software

Wireless Network Device Software MX283027A WLAN Test Software MX283027A-001 Bluetooth Test Software MX283027A-002 (Continued)

MS2830A

Recommended Configuration

• For WLAN Test Software MX283027A-001

✓✓: Required ✓: Selected ×: Not selected

Test target	2.4 GHz band			5 GHz band				
	Tx Test		Rx Test (Signal Generator*)	Tx Test		Rx Test (Signal Generator*)		
Not for Spurious Test	For Spurious Test	Not for Spurious Test		For Spurious Test				
Main Frame								
MS2830A-040	✓✓	×	✓✓ (MS2830A-020/021)	×	×	×		
MS2830A-041								✓✓
MS2830A-043								✓✓ (MS2830A-021)
MS2830A-044				✓✓			✓✓	
MS2830A-045								×
Hardware Options								
MS2830A-002	✓	✓		✓	✓			
MS2830A-005/009	✓✓	✓✓		✓✓	✓✓			
MS2830A-006								
Vector Signal Generator Options (MS2830A-020/021 cannot be installed in MS2830A-044/045.)								
MS2830A-020						×		
MS2830A-021			✓✓			✓✓		
MS2830A-022						✓✓		
MS2830A-027			✓			✓		
MS2830A-028						✓		
Software Options								
MX283027A	✓✓	✓✓	✓✓	✓✓	✓✓	✓✓		
MX283027A-001*2								

*1: Installing the Vector Signal Generator option (MS2830A-020/021) outputs WLAN signals. MS2830A-020/021 can use as a reference signal source of the Rx test. MS2830A main functions sets the pattern send count.

*2: MX283027A-001 includes MX269911A WLAN IQproducer (Cannot order MX283027A-001 and MX269911A at same time).

• For Bluetooth Test Software MX283027A-002

✓✓: Required ✓: Selected ×: Not selected

Test target	Basic Rate, Enhanced Data Rate, Bluetooth Low Energy			
	Tx Test		Rx Test (Signal Generator*)	
Not for Spurious Test	For Spurious Test			
Main Frame				
MS2830A-040	✓✓	×	✓✓ (MS2830A-020/021)	
MS2830A-041				
MS2830A-043				
MS2830A-044		✓✓		
MS2830A-045				×
Hardware Options				
MS2830A-002	✓	✓		
MS2830A-005/009	✓✓	✓✓		
MS2830A-006				
Vector Signal Generator Options (MS2830A-020/021 cannot be installed in MS2830A-044/045.)				
MS2830A-020				
MS2830A-021			✓✓	
MS2830A-022				
MS2830A-027			✓	
MS2830A-028				
Software Options				
MX283027A	✓✓	✓✓	✓✓	
MX283027A-002				

*: Installing the Vector Signal Generator option (MS2830A-020/021) outputs Bluetooth signals. MS2830A-020/021 can use as a reference signal source of the Rx test. MS2830A main functions sets the pattern send count.

Ordering Information

Model/Order No	Name	Remarks
Main Frame		
MS2830A-040	3.6 GHz Signal Analyzer	9 kHz to 3.6 GHz
MS2830A-041	6 GHz Signal Analyzer	9 kHz to 6 GHz
MS2830A-043	13.5 GHz Signal Analyzer	9 kHz to 13.5 GHz
MS2830A-044	26.5 GHz Signal Analyzer	9 kHz to 26.5 GHz
MS2830A-045	43 GHz Signal Analyzer	9 kHz to 43 GHz
Hardware Options		
MS2830A-002	High Stability Reference Oscillator	Aging rate: 1×10^{-8} /day
MS2830A-005	Analysis Bandwidth Extension to 31.25 MHz	Required for MX283027A-001/002. Option for MS2830A-040/041/043/044.
MS2830A-006	Analysis Bandwidth 10 MHz	Required for MX283027A-001/002
MS2830A-009	Bandwidth Extension to 31.25 MHz for Millimeter-wave	Required for MX283027A-001/002 and MS2830A-005/009. Option for MS2830A-045.
Vector Signal Generator Options (MS2830A-020/021 cannot be installed in MS2830A-044/045.)		
MS2830A-020	3.6 GHz Vector Signal Generator	250 kHz to 3.6 GHz
MS2830A-021	6 GHz Vector Signal Generator	250 kHz to 6 GHz
MS2830A-022	Low Power Extension for Vector Signal Generator	-136 to +15 dBm (>25 MHz), -136 to -3 dBm (≥25 MHz)
MS2830A-027	ARB Memory Upgrade 256 Msa for Vector Signal Generator	Memory: 256 Msamples (MS2830A-027 installed), 64 Msamples (MS2830A-027 not installed)
MS2830A-028	AWGN	Absolute CN Ratio: ≤40 dB
Software Options		
MX283027A	Wireless Network Device Test Software	
MX283027A-001	WLAN Test Software	MX283027A-001 includes MX269911A WLAN IQproducer (Cannot order MX283027A-001 and MX269911A at same time)
MX283027A-002	Bluetooth Test Software	

The MX283087A TRX Sweep Calibration is TRx power measurement software for the power adjustment function incorporated in femtocell base stations, etc. When the target DUT Tx and Rx powers change in a stepwise manner at each time determined by the frequency and level, this software can adjust the power quickly for each measured/output signal at a predetermined timing without repeatedly changing the measuring instruments settings.

Use of this application software requires a function for stepwise synchronization of the Tx and Rx power measurement with the DUT as well as a measurement system for synchronizing the DUT and measuring instrument.

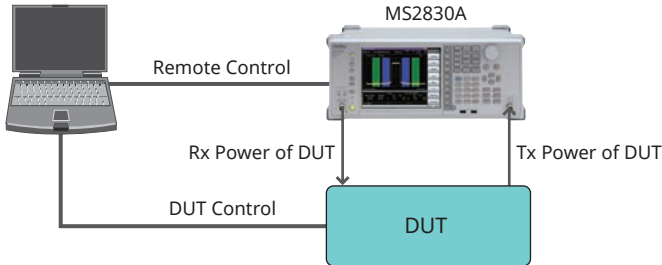

Features

- Uses signal analyzer function and installed vector signal generator option to perform high-speed TRx adjustment with one MS2830A unit
- Supports two measurement modes: TRx Mode for measuring both Tx and Rx signal simultaneously, and Rx Mode for measuring only Rx signals
- Sets frequency and level for predetermined measurement points using remote commands (program) and auto-switches frequency and level at trigger input (List Mode)

In the TRx measurement mode, the DUT is synchronized as shown in the following diagram using adjustment of the Tx and Rx powers.

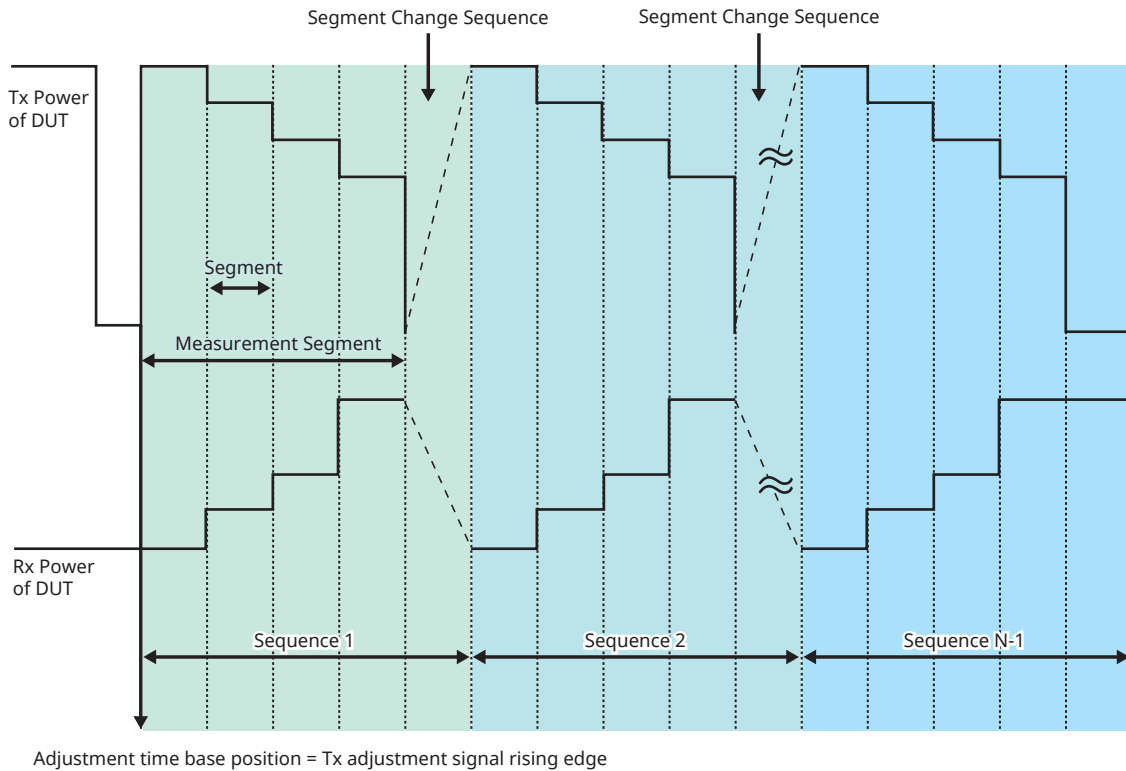

In the Rx measurement mode, the MS2830A vector signal generator outputs a trigger sequence to prepare the DUT to receive the signal and then a preprogrammed signal pattern is output for adjusting the Rx power.

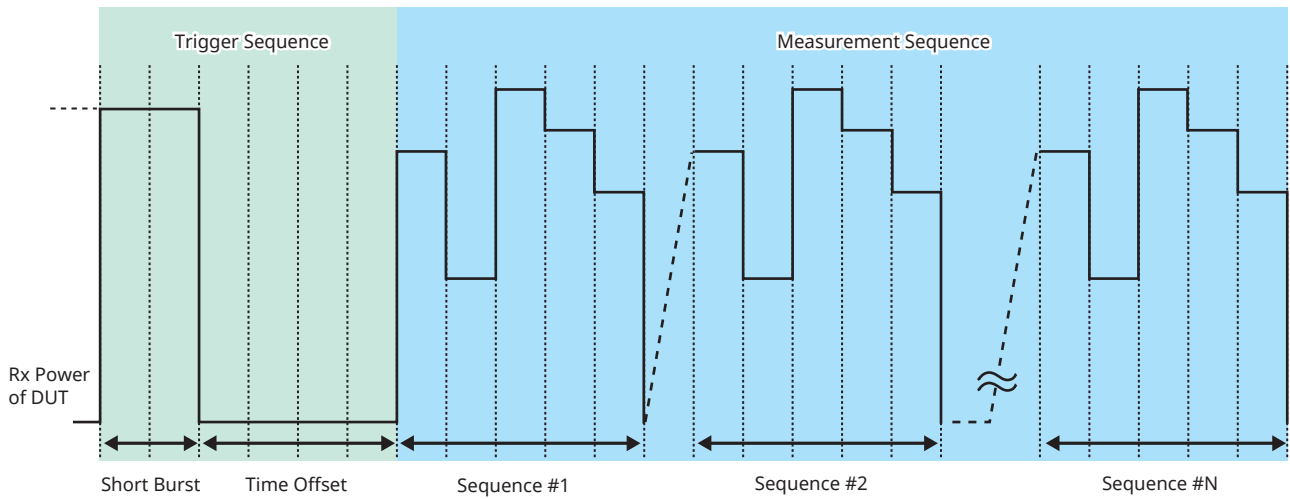

MS2830A Recommended Configuration

Model/Order No.	Name	Remarks
MS2830A-040 MS2830A-041 MS2830A-043	Signal Analyzer	MX283087A cannot be installed in MS2830A-044/045.
MX283087A	TRX Sweep Calibration	
MS2830A-006	Analysis Bandwidth 10 MHz	Necessary for MX283087A
MS2830A-005	Analysis Bandwidth Extension to 31.25 MHz	Necessary for MX283087A
MS2830A-020 MS2830A-021	3.6 GHz Vector Signal Generator 6 GHz Vector Signal Generator	Necessary for MX283087A
MS2830A-022	Low Power Extension for Vector Signal Generator	Necessary for MX283087A

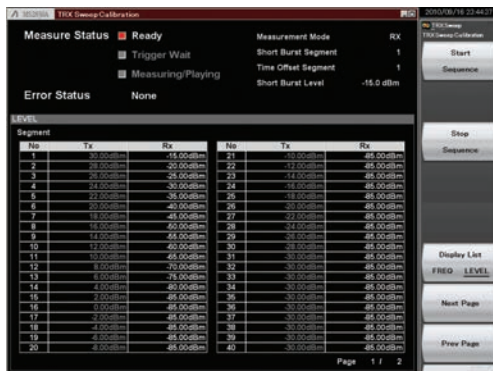

TRX Sweep Calibration Screen

Specifications

The specification is the value after 30-minute warm-up at a constant ambient temperature. Typical values are for reference only and are not guaranteed. The specifications are defined under the following condition unless otherwise specified.

Attenuator mode: Mechanical Attenuator Only (MS2830A only)

Signal Analyzer		MS2830A
Function		Performs measurement while switching both the level for each measurement unit (segment) according to the level list and the frequency for each measurement unit group (sequence) according to the frequency list.
Measurement Mode		TRX mode: Performs transmission measurement and reception measurement at the same time. RX mode: Performs reception measurement only. In the RX mode, a trigger signal, which consists of output On (active) and Off (inactive) intervals, can be output before a measurement signal.
Items Common to Transmission and Reception	Frequency Range	400 MHz to 3500 MHz
	Setting Range of Segment Length	10 ms, 20 ms
	Setting Range of Segment	1 to 80
	Setting Range of Sequence	1 to 20
Transmitter Power Measurement	Analysis Bandwidth	2.5, 5, 10, 25 MHz
	Measurement Time Range	Symmetric about the center of the segment and 20 to 90% of the specified segment length
	Trigger	Trigger mode: Free Run (Trig Off), Video (Trig On) Trigger setting range: -30 to -10 dB (compared to the measurement level specified for the first segment)
	Measured Level Range	-30 to +30 dBm
	Transmitter Power Accuracy	After CAL execution at 18° to 28°C, the input signal level is within the measurement level range, and the input level is as follows: ±0.7 dB The transmitter power accuracy is calculated from an input attenuator switching error, a measured linearity error, and a root sum square (RSS) error of the absolute amplitude accuracy and in-band frequency characteristics.
Reception Power Measurement	Output Level Range	-120 to -5 dBm
	Output Level Accuracy	CW, at 18° to 28°C ±0.5 dB (Output level ≥ -110 dBm) ±1 dB (Output level < -110 dBm) The output level accuracy is based on that of the MS2830A-020/021 Vector Signal Generator Option.
	Level Error From CW during Vector Modulation	AWGN signal whose bandwidth is 5 MHz, at 18° to 28°C, with an output frequency of 100 MHz or higher ±0.2 dB Based on the level error from CW during vector modulation with MS2830A-020/021 Vector Signal Generator Option.
	Trigger Signal	Output On interval (short burst) and Off interval (time offset) Short burst interval setting range: 1 to 100 Segment Time offset interval setting range: 1 to 100 Segment

This product was jointly developed with the National Institute of Information and Communications Technology (NICT).

Wi-SUN PHY Measurement Software MX705010A supports automatic measurement of Smart Utility Network wireless communications “Wi-SUN Alliance” PHY Conformance test cases. The MX705010A also supports automatic ARIB STD T-108 (TELEC-T245) tests. The MS269xA/MS2830A signal analyzer is controlled by remote commands from this software.

This is the ideal solution for efficient RF tests of Wi-SUN wireless equipment and improves design work.

Supports Wi-SUN RF Conformance Auto-Test

Supports automatic measurement of RF conformance test required for development and evaluation of Wi-SUN wireless equipment.

- Wi-SUN PHY Transmitter Test: Automatic measurement of Wi-SUN Alliance PHY Conformance test items
- Wi-SUN PHY Receiver Test: Supports Wi-SUN Alliance PHY Conformance test signals and Tx control methods
- ARIB STD T-108/TELEC T245 Test*1: Automatic measurement and result evaluation

*1: There is restriction by a Wi-SUN standard

Configurations

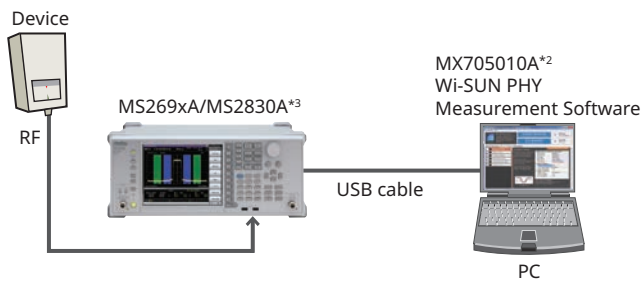

*2: Cannot be installed in MS269xA/MS2830A.

*3: Requires the latest firmware of MS269xA/MS2830A.

This service, which provides updated versions of firmware and software for downloading by product customers, is available on Anritsu's website. <<https://www.my.anritsu.com/home>>

Main frame	Options Configuration Examples
MS269xA	MX269017A, MS269xA-020, MX269902A
MS2830A	MS2830A-041, MS2830A-002, MS2830A-006, MX269017A, MS2830A-020, MS2830A-022, MS2830A-027, MX269902A

Measurement Functions

Simple operation screen

One button click starts each test



“Frequency Band ID” selects the frequency band identifier determined by IEEE 802.15.4g 2012.

“Operating Mode” automatically sets the Data Rate, Channel Spacing and Modulation Index for each mode. “Measurement Channel” is a function for automatically computing and selecting the channel corresponding to the selected operating mode.



MX2690xxA series Measurement Software

Wi-SUN PHY Measurement Software MX705010A (Continued)

MS269xA

MS2830A

• Wi-SUN Tx Test

Selects measurement items and sets parameter.
"MEASURE" button click starts automatic measurement.



Displays overall PASS/FAIL evaluation result for measurement item.
Saves measurement results as a .csv file.



• Wi-SUN Rx Test

Selects measurement items and sets parameter.
"SEND SIGNAL" button click starts RF signal sending.

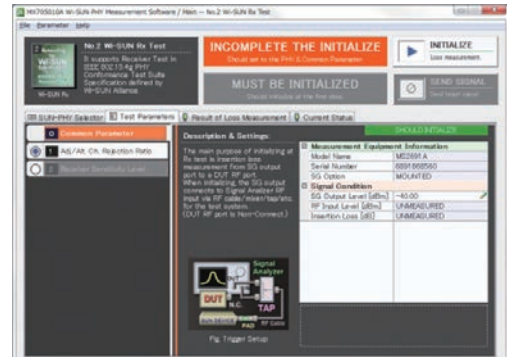

After finishing sending of specified number of PPDUs,
automatically sets RF output to OFF.

*: This software does not perform packet error rate measurement or evaluation.

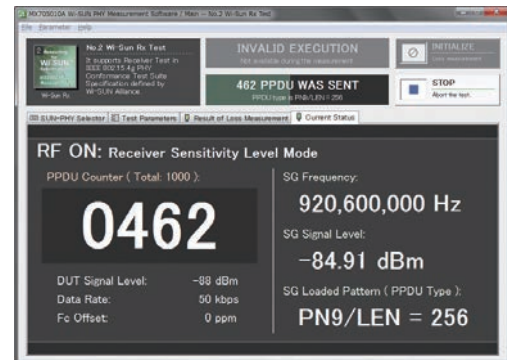

MX2690xxA series Measurement Software

Wi-SUN Protocol Monitor MX705110A

MS269xA

MS2830A

This product was jointly developed with the National Institute of Information and Communications Technology (NICT).

Wi-SUN Protocol Monitor MX705110A supports protocol analysis of Smart Utility Network wireless communications “Wi-SUN Alliance” PHY/MAC layer. The wireless signals (IEEE 802.15.4g/e, GFSK) between communicating wireless equipments are captured as I/Q data using the MS269xA/MS2830A digitize function and data analysis is performed by MX705110A. Data analysis displays the PHY/MAC frame format, Tx timing, etc.

MX705110A is a powerful tool for “Troubleshooting communications problems by checking the status of communications between wireless equipments”.

Supports Wi-SUN Wireless Communications Troubleshooting

This software analyzes the contents of the communications handled by two communications equipments to perform and confirm communications using the correct protocols.

- IEEE 802.15.4g/e (GFSK) signal analysis function
- Display for PHY layer frame data
- Display for MAC layer frame data
- Supports FCS32
- Display for RF analysis (Time vs. Tx power graph, Tx timing, Tx power)
- The analysis results are converted to a file format that can be read by Wireshark*1 and saved for later detailed analysis using the Wireshark function.

*1: Wireshark is an open source network protocol analyzer commonly used worldwide.

- Analyzing wireless equipment communications for R&D
- Checking interoperability between multiple wireless equipments

Configurations

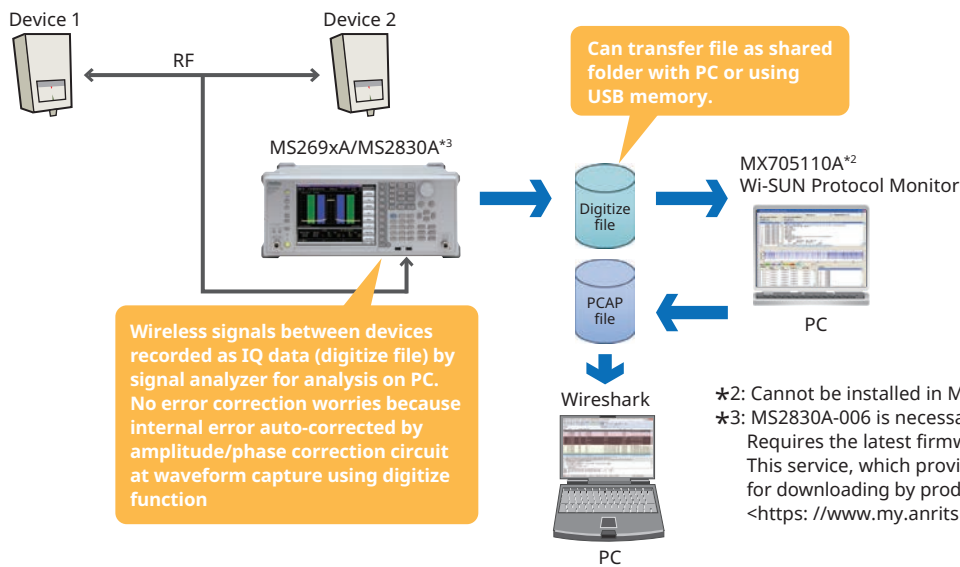

MX2690xxA series Measurement Software

Wi-SUN Protocol Monitor MX705110A (Continued)

MS269xA

MS2830A

This product was jointly developed with the National Institute of Information and Communications Technology (NICT).

Measurement Functions

- Simple operation screen

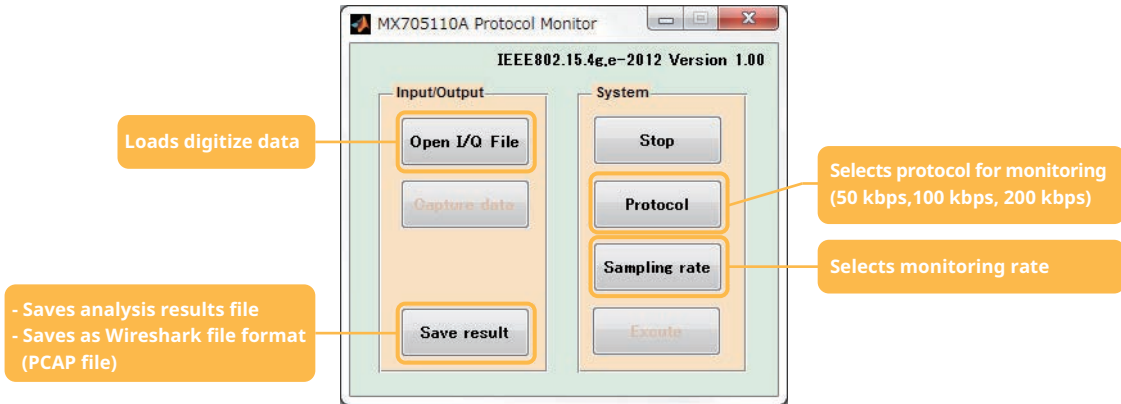

- Protocol Monitor Screen

Brings all key data together on one screen.

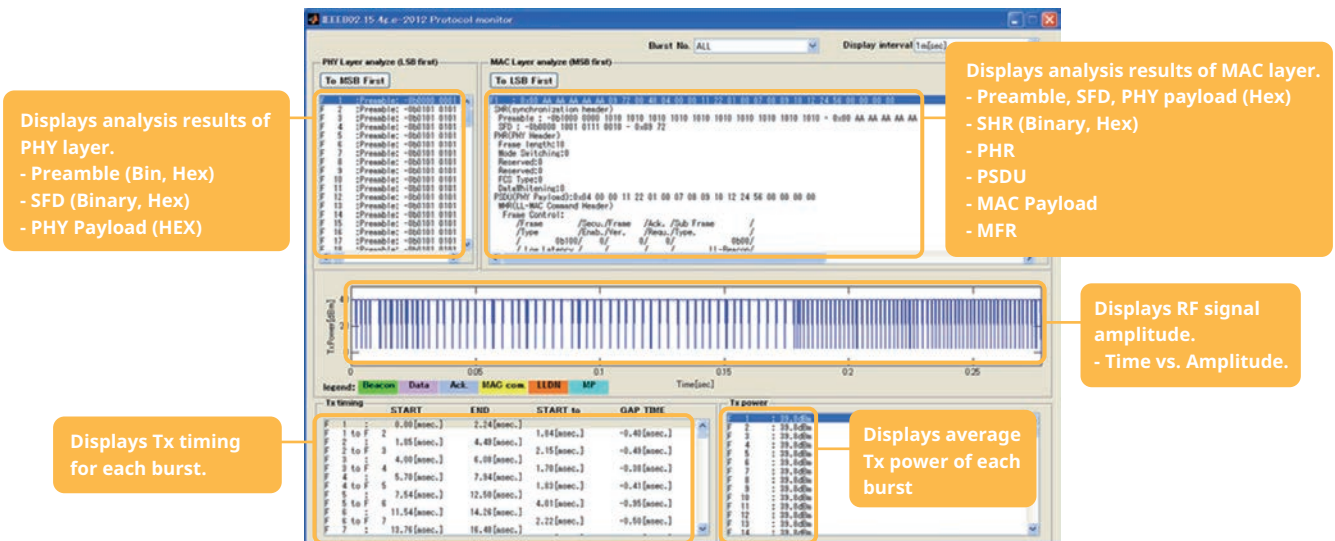

MX2690xxA series Measurement Software

MS2840A/MS2830A Configuration (Continued)

MS2840A Hardware Configuration

Frequency range (MS2840A-040/041/044/046) not upgradable.

✓ = Can be installed, No = Cannot be installed, R = Require, U = Upgrade

Opt.	Name	Retrofit	Addition to Main frame				Combination with "Opt." (Refer to the left line)																														
			040 (3.6 GHz)	041 (6 GHz)	044 (26.5 GHz)	046 (44.5 GHz)	001	002	005 (standard install)	006 (standard install)	009 (standard install)	077	078	008	069	068	010	011	016	017	026	066	067	020	021	189	022	027	028	088	029						
001	Rubidium Reference Oscillator	Yes	✓	✓	✓	✓	✗	*4																													
002	High Stability Reference Oscillator	Yes	✓	✓	Equivalent function installed	✗	*4		No				No	No									No														
005	Analysis Bandwidth Extension to 31.25 MHz	-	Standard install	Standard install	Standard install	No									No																						
006	Analysis Bandwidth 10 MHz	-	Standard install	Standard install	Standard install	Standard install																															
009	Bandwidth Extension to 31.25 MHz for Millimeter-wave	-	No	No	No	Standard install		No	No													No	No	No	No	No	No	No	No	No	No	No	No	No			
077	Analysis Bandwidth Extension to 62.5 MHz*1	Yes	✓	✓	✓	✓																															
078	Analysis Bandwidth Extension to 125 MHz*1	Yes	✓	✓	✓	✓																															
008	Preamplifier	Yes	✓	✓	✓	✓																															
069	26.5 GHz Microwave Preamplifier	Yes	No	No	✓	No		No															No	No	No	No	No	No	No	No	No	No	No	No	No	No	
068	Microwave Preamplifier	Yes	No	No	No	No		No															No	No	No	No	No	No	No	No	No	No	No	No	No	No	
010	Preamplifier	Yes	✓	✓	✓	✓																															
011	2ndary SSD	Yes	✓	✓	✓	✓																															
016	Precompliance EMI Function	Yes	✓	✓	✓	✓																															
017	Noise Figure Measurement Function	Yes	✓	✓	✓	✓																															
026	BER Measurement Function	Yes	✓	✓	✓	✓																															
066	Low Phase Noise Performance	Yes	✓	✓	No	No							No											No													
067	Microwave Preselector Bypass	Yes	No	No	✓	✓		No														No	No	No	No	No	No	No	No	No	No	No	No	No	No	No	
020	3.6 GHz Vector Signal Generator	Yes	✓	✓	No	No						No			No	No							No	No	No	No	No	No	No	No	No	No	No	No	No	No	
021	6 GHz Vector Signal Generator	Yes	✓	✓	No	No						No			No	No							No	No	No	No	No	No	No	No	No	No	No	No	No	No	
189	Vector Function Extension for Analog Signal Generator Retrofit	Yes	✓	✓	No	No						No			No	No							No	No	No	No	No	No	No	No	R	No	No	No	No		
022	Low Power Extension for Vector Signal Generator	Yes	✓	✓	No	No						No			No	No							No	R	No	No	No	No	No	No	No	No	No	No	No	No	
027	ARB Memory Upgrade 256 Msa for Vector Signal Generator*2	Yes	✓	✓	No	No						No			No	No							No	R	No	No	No	No	No	No	No	No	No	No	No	No	
028	AWGN*2	Yes	✓	✓	No	No						No			No	No							No	R	No	No	No	No	No	No	No	No	No	No	No	No	
088	3.6 GHz Analog Signal Generator*3	Yes	✓	✓	No	No						No			No	No							No	No	No	No	No	No	No	No	No	No	No	No	No	No	
029	Analog Function Extension for Vector Signal Generator*3	Yes	✓	✓	No	No						No			No	No							No	R	No	R	No	No	No	No	No	No	No	No	No	No	

*1: An image response is received when setting the bandwidth to more than 31.25 MHz.

This can be used when not inputting a signal frequency outside the MS2830A analysis bandwidth (125 MHz max.).

The Signal Analyzer MS2690A/91A/92A series is recommended for other measurement purposes.

*2: The ARB Memory Upgrade 256 Msa for Vector Signal Generator (MS2840A-027) and AWGN (MS2840A-028) are non-functional in the Analog Signal Generator (MS2840A-029/088).

*3: Requires Analog Measurement Software (MX269018A).

*4: The Rubidium Reference Oscillator can be retrofitted to the MS2840A-040/041 with installed High Stability Reference Oscillator.

In this case, the Rubidium Reference Oscillator is functional.

*5: The 26.5 GHz Microwave Preamplifier or Microwave Preamplifier can be retrofitted to the MS2830A-044/046 with installed Preamplifier.

In this case, the 26.5 GHz Microwave Preamplifier or Microwave Preamplifier are functional.

MX2690xxA series Measurement Software

MS2840A/MS2830A Configuration (Continued)

MS2830A Software Configuration

✓ = Can be installed, No = Cannot be installed, R = Require, U = Upgrade

Model	Name	Addition to Main frame					Analysis Bandwidth					Note
		MS2830A-040 (3.6 GHz)	MS2830A-041 (6 GHz)	MS2830A-043 (13.5 GHz)	MS2830A-044 (26.5 GHz)	MS2830A-045 (43 GHz)	MS2830A-005 (31.25 MHz)	MS2830A-006 (10 MHz)	MS2830A-009 (31.25 MHz)	MS2830A-077 (62.5 MHz)	MS2830A-078 (125 MHz)	
MX269010A	Mobile WiMAX Measurement Software	✓	✓	✓	✓	No	R	R	No			
MX269011A	W-CDMA/HSPA Downlink Measurement Software	✓	✓	✓	✓	✓		R				
MX269012A	W-CDMA/HSPA Uplink Measurement Software	✓	✓	✓	✓	✓		R				
MX269013A	GSM/EDGE Measurement Software	✓	✓	✓	✓	✓		R				
MX269013A-001	EDGE Evolution Measurement Software	✓	✓	✓	✓	✓		R				Require MX269013A
MX269015A	TD-SCDMA Measurement Software	✓	✓	✓	✓	✓		R				
MX269017A	Vector Modulation Analysis Software	✓	✓	✓	*3	*3	U	R	*1	U	U	U: Upgrade of the phase noise performance (MS2830A-066) (Measured signal: Frequency <3.6 GHz, Bandwidth <1 MHz)
MX269018A	Analog Measurement Software	✓	✓	*2	No	No			No			Require MS2830A-066 and A0086B (See MX2690xxA series Measurement Software catalog for detail) Note) MS2830A-043 cannot implement a signal generator for Rx test (Because MS2830A-066 is required)
MX269020A	LTE Downlink Measurement Software	✓	✓	✓	✓	✓	R	R	*1			
MX269020A-001	LTE-Advanced FDD Downlink Measurement Software	✓	✓	✓	✓	✓	R	R	*1	U	U	Require MX269020A
MX269021A	LTE Uplink Measurement Software	✓	✓	✓	✓	✓	R	R	*1			
MX269021A-001	LTE-Advanced FDD Uplink Measurement Software	✓	✓	✓	✓	✓	R	R	*1	U	U	Require MX269021A
MX269022A	LTE TDD Downlink Measurement Software	✓	✓	✓	✓	✓	R	R	*1			
MX269022A-001	LTE-Advanced TDD Downlink Measurement Software	✓	✓	✓	✓	✓	R	R	*1	U	U	Require MX269022A
MX269023A	LTE TDD Uplink Measurement Software	✓	✓	✓	✓	✓	R	R	*1			
MX269023A-001	LTE-Advanced TDD Uplink Measurement Software	✓	✓	✓	✓	✓	R	R	*1	U	U	Require MX269023A
MX269024A	CDMA2000 Forward Link Measurement Software	✓	✓	✓	✓	✓		R				
MX269024A-001	All Measure Function	✓	✓	✓	✓	✓		R				Require MX269024A
MX269026A	EV-DO Forward Link Measurement Software	✓	✓	✓	✓	✓		R				
MX269026A-001	All Measure Function	✓	✓	✓	✓	✓		R				Require MX269026A
MX269028A	WLAN (802.11) Measurement Software	✓	✓	✓	✓	✓	R	R	*1			
MX269028A-001	802.11ac (80 MHz) Measurement Software	✓	✓	✓	✓	✓	R	R	*1	R	R	Only for MS2830A. Require MX269028A
MX269030A	W-CDMA BS Measurement Software	✓	✓	✓	✓	✓		R				
MX283027A	Wireless Network Device Test Software	↓	↓	↓	↓	↓	↓	↓	↓			
MX283027A-001	WLAN Test Software	✓	✓	✓	✓	✓	R	R	*1			Require MX283027A*4
MX283027A-002	Bluetooth Test Software	✓	✓	✓	✓	✓	R	R				Require MX283027A
MX283087A	TRX Sweep Calibration	✓	✓	✓	No	No	R	R				Require MS2830A-020/021 and MS2830A-022

*1: MS2830A-045 cannot be installed MS2830A-005. Add MS2830A-009 in substitution for MS2830A-005.

*2: MS2830A-043 can implement only either MS2830A-020/021 or MS2830A-066.

By the system that MS2830A-066 is necessary, MS2830A-020/021 is not added to MS2830A-043.

*3: By the measurement of the narrowband signal, add MS2830A-066. (Channel bandwidth: x kHz to 100 kHz)

MS2830A-044/045 cannot be installed MS2830A-066.

*4: MX283027A-001 includes MX269911A WLAN IQproducer (Cannot order MX283027A-001 and MX269911A at same time).

MS2840A Software Configuration

✓ = Can be installed, No = Cannot be installed, R = Require, U = Upgrade

Model	Name	Addition to Main frame				Analysis Bandwidth		Note
		MS2840A-040 (3.6 GHz)	MS2840A-041 (6 GHz)	MS2840A-044 (26.5 GHz)	MS2840A-046 (44.5 GHz)	MS2840A-077 (62.5 MHz)	MS2840A-078 (125 MHz)	
MX269017A	Vector Modulation Analysis Software	✓	✓	✓	✓	✓	✓	
MX269018A	Analog Measurement Software	✓	✓	✓	✓			Require A0086B

MX2690xxA series Measurement Software

Ordering Information

Please specify the model/order number, name and quantity when ordering.
The names listed in the chart below are Order Names. The actual name of the item may differ from the Order Name.

Model/Order No	Name
	Main frame
MS2690A	Signal Analyzer (50 Hz to 6 GHz)
MS2691A	Signal Analyzer (50 Hz to 13.5 GHz)
MS2692A	Signal Analyzer (50 Hz to 26.5 GHz)
MS2840A-040	Signal Analyzer (9 kHz to 3.6 GHz)
MS2840A-041	Signal Analyzer (9 kHz to 6 GHz)
MS2840A-044	Signal Analyzer (9 kHz to 26.5 GHz)
MS2840A-046	Signal Analyzer (9 kHz to 44.5 GHz)
MS2830A-040	Signal Analyzer (9 kHz to 3.6 GHz)
MS2830A-041	Signal Analyzer (9 kHz to 6 GHz)
MS2830A-043	Signal Analyzer (9 kHz to 13.5 GHz)
MS2830A-044	Signal Analyzer (9 kHz to 26.5 GHz)
MS2830A-045	Signal Analyzer (9 kHz to 43 GHz)
	Software options
	CD-ROM with license and operation manuals
MX269010A	Mobile WiMAX Measurement Software
MX269011A	W-CDMA/HSPA Downlink Measurement Software
MX269012A	W-CDMA/HSPA Uplink Measurement Software
MX269013A	GSM/EDGE Measurement Software
MX269013A-001	EDGE Evolution Measurement Software (Requires MX269013A)
MX269014A	ETC/DSRC Measurement Software (MS269xA only)
MX269015A	TD-SCDMA Measurement Software
MX269017A	Vector Modulation Analysis Software
MX269018A	Analog Measurement Software (For MS2840A and MS2830A. MS2830A-066 and A0086B are required for MS2830A. A0086B is required for MS2840A.)
MX269020A	LTE Downlink Measurement Software
MX269020A-001	LTE-Advanced FDD Downlink Measurement Software (Requires MX269020A)
MX269021A	LTE Uplink Measurement Software
MX269021A-001	LTE-Advanced FDD Uplink Measurement Software (Requires MX269021A)
MX269022A	LTE TDD Downlink Measurement Software
MX269022A-001	LTE-Advanced TDD Downlink Measurement Software (Requires MX269022A)
MX269023A	LTE TDD Uplink Measurement Software
MX269023A-001	LTE-Advanced TDD Uplink Measurement Software (Requires MX269023A)
MX269024A	CDMA2000 Forward Link Measurement Software
MX269024A-001	All Measure Function (Requires MX269024A)
MX269026A	EV-DO Forward Link Measurement Software
MX269026A-001	All Measure Function (Requires MX269026A)
MX269028A	WLAN (802.11) Measurement Software
MX269028A-001	802.11ac (80 MHz) Measurement Software (MS2830A only, Requires MX269028A)
MX269028A-002	802.11ac (160 MHz) Measurement Software (MS269xA only, Requires MX269028A)
MX269030A	W-CDMA BS Measurement Software
MX283027A	Wireless Network Device Test Software
MX283027A-001	WLAN Test Software (Requires MX283027A)
MX283027A-002	Bluetooth Test Software (Requires MX283027A)
MX283087A	TRX Sweep Calibration

Model/Order No	Name
	Measurement Software Options
	These software are for PC.
MX705010A*	Wi-SUN PHY Measurement Software (For MS269xA and MS2830A)
MX705110A	Wi-SUN Protocol Monitor (For MS269xA and MS2830A. MS2830A-006 is necessary for MS2830A.)
	Application parts
W2919AE	MX269010A Operation Manual (Operation)
W2954AE	MX269010A Operation Manual (Remote Control)
W3098AE	MX269011A Operation Manual (Operation)
W3099AE	MX269011A Operation Manual (Remote Control)
W3060AE	MX269012A Operation Manual (Operation)
W3061AE	MX269012A Operation Manual (Remote Control)
W3100AE	MX269013A Operation Manual (Operation)
W3101AE	MX269013A Operation Manual (Remote Control)
W3031AE	MX269014A Operation Manual (Operation) (MS269xA only)
W3032AE	MX269014A Operation Manual (Remote Control) (MS269xA only)
W3044AE	MX269015A Operation Manual (Operation)
W3045AE	MX269015A Operation Manual (Remote Control)
W3305AE	MX269017A Operation Manual (Operation)
W3306AE	MX269017A Operation Manual (Remote Control)
W3555AE	MX269018A Operation Manual (Operation) (MS2830A only)
W3556AE	MX269018A Operation Manual (Remote Control) (MS2830A only)
W3014AE	MX269020A Operation Manual (Operation)
W3064AE	MX269020A Operation Manual (Remote Control)
W3015AE	MX269021A Operation Manual (Operation)
W3065AE	MX269021A Operation Manual (Remote Control)
W3209AE	MX269022A Operation Manual (Operation)
W3210AE	MX269022A Operation Manual (Remote Control)
W3521AE	MX269023A Operation Manual (Operation)
W3522AE	MX269023A Operation Manual (Remote Control)
W3201AE	MX269024A Operation Manual (Operation)
W3202AE	MX269024A Operation Manual (Remote Control)
W3203AE	MX269026A Operation Manual (Operation)
W3204AE	MX269026A Operation Manual (Remote Control)
W3528AE	MX269028A Operation Manual (Operation)
W3529AE	MX269028A Operation Manual (Remote Control)
W2860AE	MX269030A Operation Manual (Operation)
W2861AE	MX269030A Operation Manual (Remote Control)
W3471AE	MX283027A Operation Manual (Operation)
W3473AE	MX283027A-001 Operation Manual (Operation)
W3474AE	MX283027A-001 Operation Manual (Remote Control)
W3516AE	MX283027A-002 Operation Manual (Operation)
W3517AE	MX283027A-002 Operation Manual (Remote Control)
W3448AE	MX283087A Operation Manual (Operation)
W3449AE	MX283087A Operation Manual (Remote Control)

☆:	Main frame	Options configuration examples
	MS269xA	MX269017A, MS269xA-020, MX269902A
	MS2830A	MS2830A-041, MS2830A-002, MS2830A-006, MX269017A, MS2830A-020, MS2830A-022, MS2830A-027, MX269902A

• United States

Anritsu Company

1155 East Collins Blvd., Suite 100, Richardson,
TX 75081, U.S.A.

Toll Free: 1-800-267-4878

Phone: +1-972-644-1777

Fax: +1-972-671-1877

• Canada

Anritsu Electronics Ltd.

700 Silver Seven Road, Suite 120, Kanata,

Ontario K2V 1C3, Canada

Phone: +1-613-591-2003

Fax: +1-613-591-1006

• Brazil

Anritsu Eletronica Ltda.

Praça Amadeu Amaral, 27 - 1 Andar

01327-010 - Bela Vista - Sao Paulo - SP

Brazil

Phone: +55-11-3283-2511

Fax: +55-11-3288-6940

• Mexico

Anritsu Company, S.A. de C.V.

Av. Ejército Nacional No. 579 Piso 9, Col. Granada

11520 México, D.F., México

Phone: +52-55-1101-2370

Fax: +52-55-5254-3147

• United Kingdom

Anritsu EMEA Ltd.

200 Capability Green, Luton, Bedfordshire, LU1 3LU, U.K.

Phone: +44-1582-433200

Fax: +44-1582-731303

• France

Anritsu S.A.

12 avenue du Québec, Bâtiment Iris 1- Silic 612,

91140 VILLEBON SUR YVETTE, France

Phone: +33-1-60-92-15-50

Fax: +33-1-64-46-10-65

• Germany

Anritsu GmbH

Nemetschek Haus, Konrad-Zuse-Platz 1

81829 München, Germany

Phone: +49-89-442308-0

Fax: +49-89-442308-55

• Italy

Anritsu S.r.l.

Via Elio Vittorini 129, 00144 Roma, Italy

Phone: +39-6-509-9711

Fax: +39-6-502-2425

• Sweden

Anritsu AB

Kistagången 20B, 164 40 KISTA, Sweden

Phone: +46-8-534-707-00

Fax: +46-8-534-707-30

• Finland

Anritsu AB

Teknobulevardi 3-5, FI-01530 VANTAA, Finland

Phone: +358-20-741-8100

Fax: +358-20-741-8111

• Denmark

Anritsu A/S

Kay Fiskers Plads 9, 2300 Copenhagen S, Denmark

Phone: +45-7211-2200

Fax: +45-7211-2210

• Russia

Anritsu EMEA Ltd.

Representation Office in Russia

Tverskaya str. 16/2, bld. 1, 7th floor.

Moscow, 125009, Russia

Phone: +7-495-363-1694

Fax: +7-495-935-8962

• Spain

Anritsu EMEA Ltd.

Representation Office in Spain

Edificio Cuzco IV, Po. de la Castellana, 141, Pta. 8

28046, Madrid, Spain

Phone: +34-915-726-761

Fax: +34-915-726-621

• United Arab Emirates

Anritsu EMEA Ltd.

Dubai Liaison Office

902, Aurora Tower,

P O Box: 500311 - Dubai Internet City

Dubai, United Arab Emirates

Phone: +971-4-3758479

Fax: +971-4-4249036

• India

Anritsu India Private Limited

2nd & 3rd Floor, #837/1, Binnamangla 1st Stage,

Indiranagar, 100ft Road, Bangalore - 560038, India

Phone: +91-80-4058-1300

Fax: +91-80-4058-1301

• Singapore

Anritsu Pte. Ltd.

11 Chang Charn Road, #04-01, Shriro House

Singapore 159640

Phone: +65-6282-2400

Fax: +65-6282-2533

• P.R. China (Shanghai)

Anritsu (China) Co., Ltd.

Room 2701-2705, Tower A,

New Caohejing International Business Center

No. 391 Gui Ping Road Shanghai, 200233, P.R. China

Phone: +86-21-6237-0898

Fax: +86-21-6237-0899

• P.R. China (Hong Kong)

Anritsu Company Ltd.

Unit 1006-7, 10/F., Greenfield Tower, Concordia Plaza,

No. 1 Science Museum Road, Tsim Sha Tsui East,

Kowloon, Hong Kong, P.R. China

Phone: +852-2301-4980

Fax: +852-2301-3545

• Japan

Anritsu Corporation

8-5, Tamura-cho, Atsugi-shi, Kanagawa, 243-0016 Japan

Phone: +81-46-296-6509

Fax: +81-46-225-8359

• Korea

Anritsu Corporation, Ltd.

5FL, 235 Pangyoyeok-ro, Bundang-gu, Seongnam-si,

Gyeonggi-do, 13494 Korea

Phone: +82-31-696-7750

Fax: +82-31-696-7751

• Australia

Anritsu Pty. Ltd.

Unit 20, 21-35 Ricketts Road,

Mount Waverley, Victoria 3149, Australia

Phone: +61-3-9558-8177

Fax: +61-3-9558-8255

• Taiwan

Anritsu Company Inc.

7F, No. 316, Sec. 1, NeiHu Rd., Taipei 114, Taiwan

Phone: +886-2-8751-1816

Fax: +886-2-8751-1817